

未注公差/General tolerances(mm)													0.1/10
0	>3	>6	>10	>18	>30	>50	>80	>120	>180	>250	>315	>400	
~3	~6	~10	~18	~30	~50	~80	~120	~180	~250	~315	~400	~500	
±0.12	±0.18	±0.22	±0.26	±0.31	±0.37	±0.57	±0.80	±0.93	±1.05	±1.15	±1.60	±2.20	±2.50
													±2'

DGH25J-01P-1Y-00A&Z(H)
(W/O COVER)

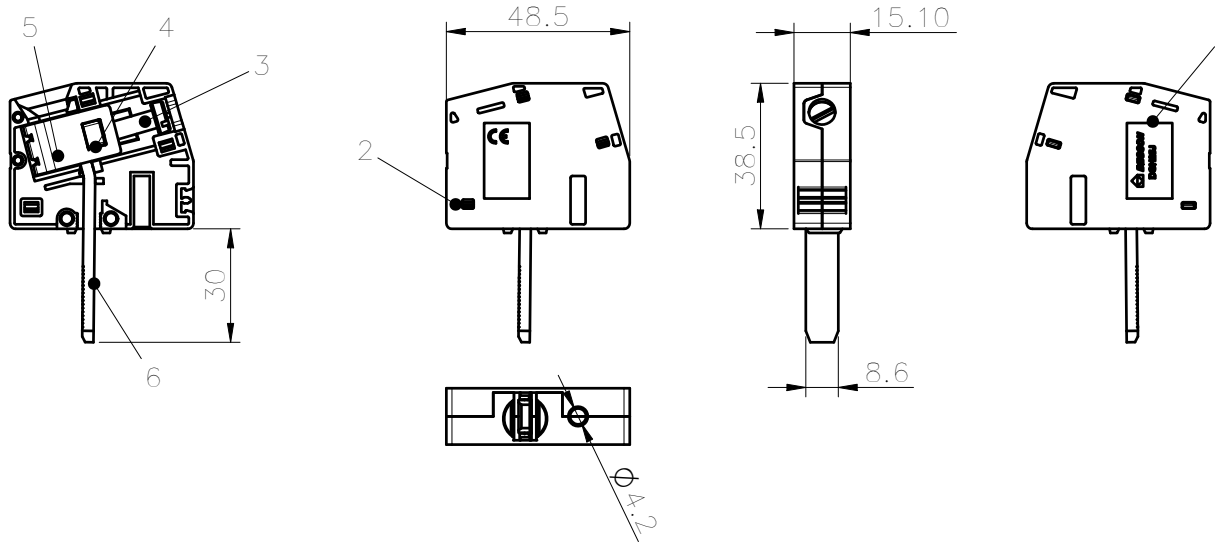

DGH25K-01P-1Y-00A&Z(H)
(W/O COVER)

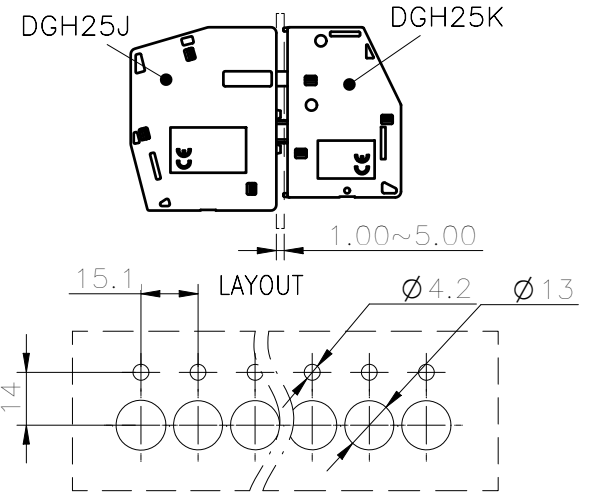
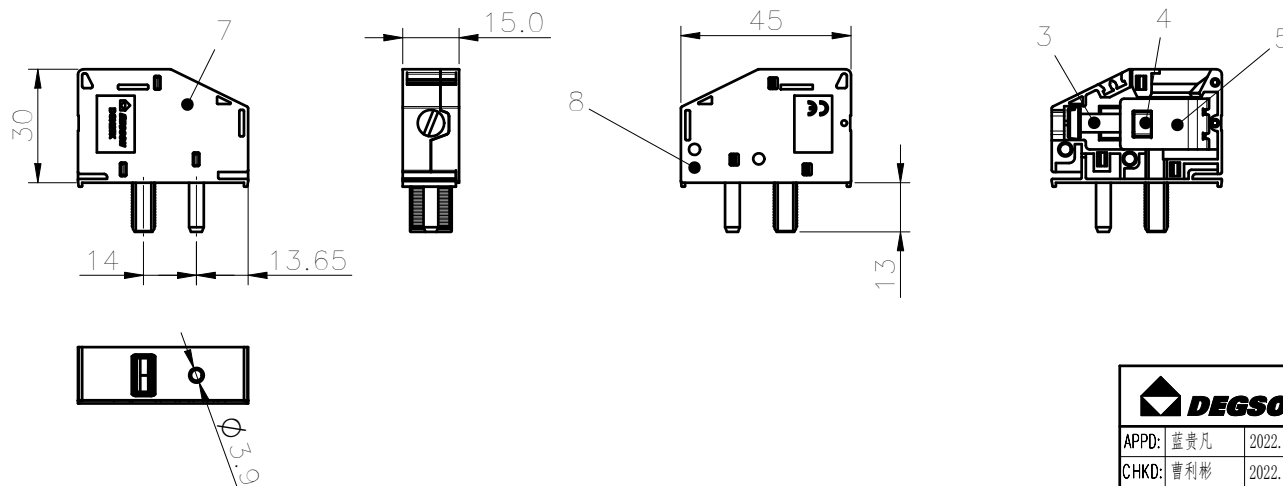

Note: The A&Z(H) in the name means: A(H) and Z(H).

8	HousingK-1	PA66	UL94V-0
7	HousingK-2	PA66	UL94V-0
6	Current carrier	Copper	Sn Plated
5	Fe cage	SPCC	Zn Plated
4	Cu cage	Copper alloy	Ni Plated
3	Screw	Steel	Zn Plated
2	HousingJ-1	PA66	UL94V-0
1	HousingJ-2	PA66	UL94V-0
ITEM	NAME OF PART	MATERIAL	NOTES

UL 标准/UL Standard:	B	C	D
额定电压/电流/Rated Voltage(V)/Current(A)	600/115	/	/
IEC 标准/IEC Standard:			
过压类别/Overvoltage Category/污染等级/Pollution Degree	III/3	III/2	II/2
额定电压/电流/Rated Voltage(V)/Current(A)	500/101	/	/
额定脉冲电压(KV)/Rate Impulse Voltage(KV)	6	/	/
螺丝扭矩/Torque Tightening(N·m/Lb·in)	M5, 4.0/35.44		
线径范围(硬线和软线)/Wire Range(rigid and flexible)(AWG/mm ²)	8~2/ 6~30(sol) 10~25(str)		
间距/Pitch(mm)/线数范围/Poles	15.1/N=01P		
剥线长度/Stripping length(mm)	19.0		
使用温度范围/Operating temperature(°C)	-40~+105		
符合 RoHS 环保要求/Conform to RoHS	Yes		



MATERIAL:	SURFACE:
MAT NO./REV: - / 00	MAT STATUS: 批量

APPD: 蓝贵凡	2022.12.07
CHKD: 曹利彬	2022.12.07
DRFT: 姜民洁	2022.12.07

NAME		DGH25-01P-1Y-00A&Z(H)	
DRAWING NO.	TYPE	DRAWING STATUS	SCALE
200016627	CUSTOMER DRAWING	已发布	2:1
SHEET		1/1	

00	ECN	DESCRIPTION	DRFT	DATE
REV	ECN	DESCRIPTION	DRFT	DATE

Transfer or duplication of this document as well as the utilization or communication of its contents are prohibited unless written permission is granted. Degson will be liable for compensation. All rights reserved for patent, utility model or design registrations. 非经书面明确授权, 否则禁止转让、复制、利用、交流本文件的内容。一经发现侵权, 本公司保留对侵权人、侵权产品进行追责的权利。