

PCB LAYOUT

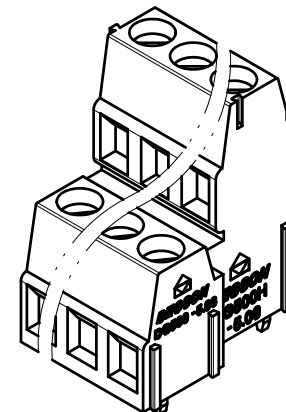
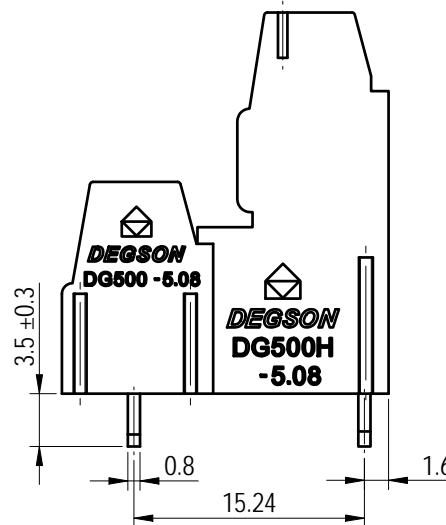
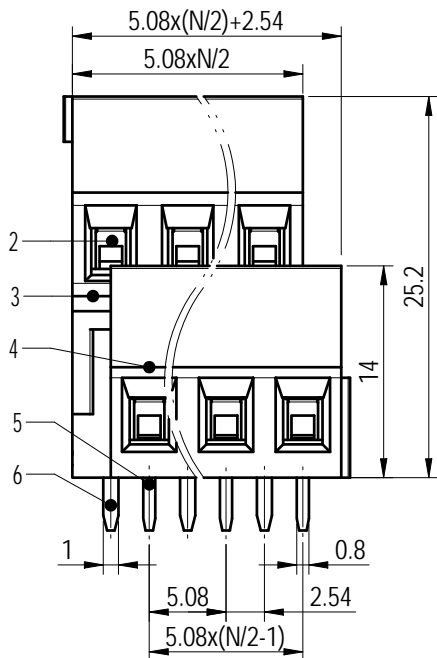
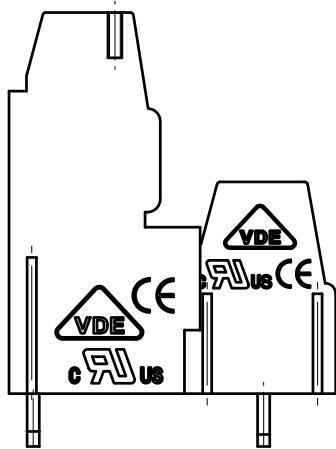
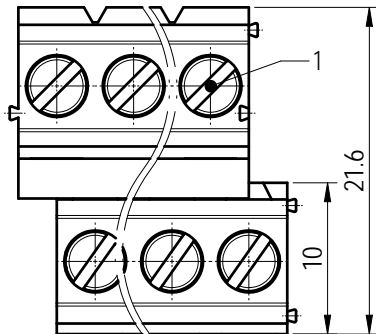
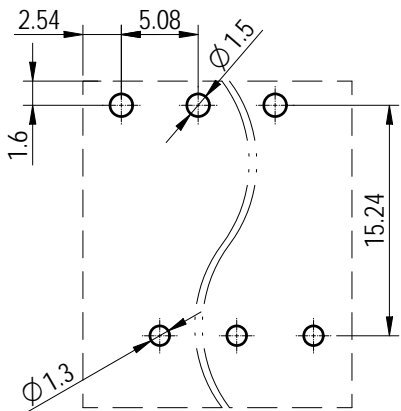

未注公差/General tolerances (mm)												0.1/10	
0	>3	>6	>10	>18	>30	>50	>80	>120	>180	>250	>315		>400
~3	~6	~10	~18	~30	~50	~80	~120	~180	~250	~315	~400	~500	>500
±0.12	±0.18	±0.22	±0.26	±0.31	±0.37	±0.57	±0.80	±0.93	±1.05	±1.15	±1.60	±2.20	±2.50

UL 标准/UL Standard:	B	C	D
额定电压/电流/Rated Voltage(V)/Current(A)	300/20	/	300/10
IEC 标准/IEC Standard:			
过压类别/Overvoltage Category/污染等级/Pollution Degree	III/3	III/2	II/2
额定电压/电流/Rated Voltage(V)/Current(A)	/	250/18	/
工频耐压/Withstanding Voltage(V/1Min)	AC2000		
螺丝扭矩/Torque Tightening(N·m/Lb.in)	M3, 0.5/4.5		
线径范围(硬线和软线)/Wire Range(rigid and flexible)(AWG/mm²)	28~12 / 1.0~2.5		
间距/Pitch(mm)/线数范围/Poles	5.08/N=04~48P		
剥线长度/Stripping length(mm)	6~7		
使用温度范围/Operating temperature(°C)	-40~+105		
符合RoHS环保要求/Conform to RoHS	Yes		

ITEM	NAME OF PART	MATERIAL	NOTES
6	Pin header2	Copper Alloy	Sn Plated
5	Pin header1	Copper Alloy	Sn Plated
4	Housing1	PA66	UL94V-0
3	Housing2	PA66	UL94V-0
2	Cage	Copper Alloy	M2.5/Ni Plated
1	Screw	Steel	M2.5/Zn Plated

		MATERIAL:	SURFACE/COLOR:		
APPD: 兰春华	2024.03.22	MAT NO./REV:	/ 00		
CHKD: 陈招	2024.03.22	NAME			
DRFT: 龚徐涛	2024.03.21	DG500A-5.08-XXP-1Y-1000A&Z(H)			
DRAWING NO.	TYPE	DRAWING STATUS	SCALE	SHEET	
200025213	CUSTOMER DRAWING	已发布	2:1	1/1	

REV	ECN	DESCRIPTION	DRFT	DATE
01		长宽尺寸修正	龚徐涛	2024.03.21

Transfer or duplication of this document as well as the utilization or communication of its contents are prohibited unless authorized in writing. All rights reserved for patent. 除专利注明授权外，未经许可，不得复制或传播。 未经授权，不得复制或传播。 未经授权，不得复制或传播。