

PCB LAYOUT

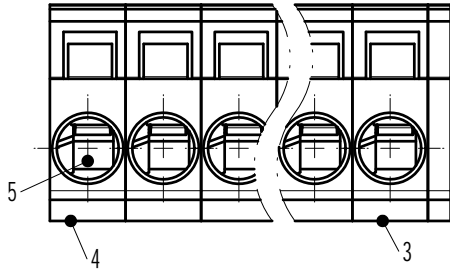

公差/General tolerances (mm)													0.1/10 ±2'
0	>3	>6	>10	>18	>30	>50	>80	>120	>180	>250	>315	>400	
~3	~6	~10	~18	~30	~50	~80	~120	~180	~250	~315	~400	~500	>500
±0.12	±0.18	±0.22	±0.26	±0.31	±0.37	±0.57	±0.80	±0.93	±1.05	±1.15	±1.60	±2.20	±2.50

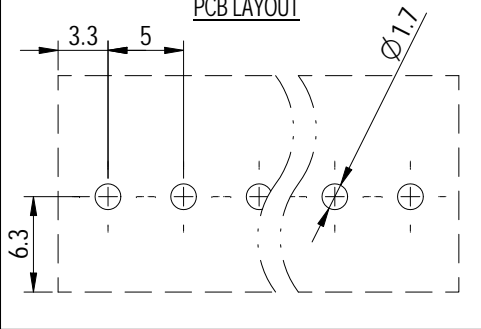
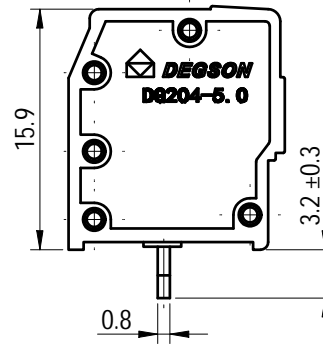
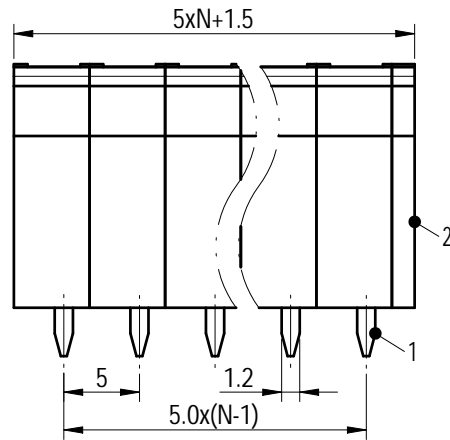
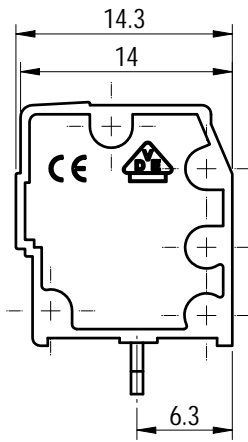
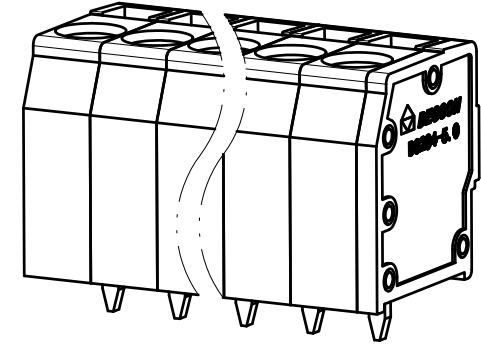

Note: The A&Z(H) in the name means: A(H) and Z(H).

ITEM	NAME OF PART	MATERIAL	NOTES
5	Spring	Stainless steel	/
4	Side housing	PA66	UL94V-0
3	Housing	PA66	UL94V-0
2	Cover	PA66	UL94V-0
1	Pin header	Copper	Sn Plated

UL 标准/UL Standard:	B	C	D
额定电压/电压/Rated Voltage(V)/Current(A)	300/12	/	/
IEC 标准/IEC Standard:			
过压类别/Overvoltage Category/污染等级/Pollution Degree	III/3	III/2	II/2
额定电压/电压/Rated Voltage(V)/Current(A)	320/20	400/20	630/20
额定脉冲电压(KV)/Rate Impulse Voltage(KV)	4	4	4
线径范围(硬线和软线)/Wire Range(rigid and flexible)(AWG/mm²)	28~14 / 0.2~2.5		
间距/Pitch(mm)/线数范围/Poles	5.0/N=01~26P		
剥线长度/Stripping length(mm)	8~9		
使用温度范围/Operating temperature(°C)	-40~+105		
符合RoHS环保要求/Conform to RoHS	Yes		

DEGSON		MATERIAL: -	SURFACE/COLOR:	
APPD: 兰春华 2022.09.23		MAT NO./REV: - / 00	MAT STATUS: 批量	
CHKD: 陈招 2022.09.22		NAME		
DRFT: 袁路易 2022.09.22		DG204-5.0-XXP-1Y-00A&Z(H)		
DRAWING NO.	TYPE	DRAWING STATUS	SCALE	SHEET
200022146	CUSTOMER DRAWING	已发布	2:1	1/1

REV	ECN	DESCRIPTION	DRFT	DATE
00			袁路易	2022.09.22

Transfer or duplication of this document as well as the utilization or communication of its contents are prohibited unless authorized in writing. All rights reserved for patent. 除专利号明确标注外, 其他标注均非专利。 未经授权, 禁止复制或传播。 未经授权, 禁止复制或传播。 未经授权, 禁止复制或传播。 未经授权, 禁止复制或传播。