

未注公差/General tolerances(mm)											
0	>3	>6	>10	>18	>30	>50	>80	>120	>180	>250	0.1/10 /
~3	~6	~10	~18	~30	~50	~80	~120	~180	~250	~315	
±0.12 ±0.18 ±0.22 ±0.26 ±0.31 ±0.37 ±0.57 ±0.80 ±1.03 ±1.05 ±1.15 ±1.60 ±2.20 ±2.50 ±2											
UL 标准/UL Standard:								B	C	D	
额定电压/电流/Rated Voltage(V)/Current(A)								600/155	600/155	600/5	
IEC 标准/IEC Standard:											
过压类别/Overvoltage Category/污染等级/Pollution Degree								III/3	III/2	II/2	
额定电压/电流/Rated Voltage(V)/Current(A)								1000/155	1000/155	1000/155	
额定脉冲电压(KV)/Rate Impulse Voltage(KV)								8	8	8	
螺丝扭矩/Torque Tightening(N·m/Lb.in)								M8, 4.5/40.00			
线径范围(硬线和软线)/Wire Range(rigid and flexible)(AWG/mm²)								20~2/0 / 0.5~ 70			
间距/Pitch(mm)/线数范围/Poles								27.00/N=01~12P			
使用温度范围/Operating temperature(°C)								-40~+120			

Tramroad Refer to table "H":	
12P	370.2±3.0
11P	345.2±3.0
10P	320.2±3.0
09P	295.2±3.0
08P	270.2±3.0
07P	245.2±3.0
06P	220.2±3.0
05P	170.2±3.0
04P	145.2±3.0
03P	120.2±3.0
02P	95.2±3.0
01P	70.2±3.0
POLES (N)	L (mm)

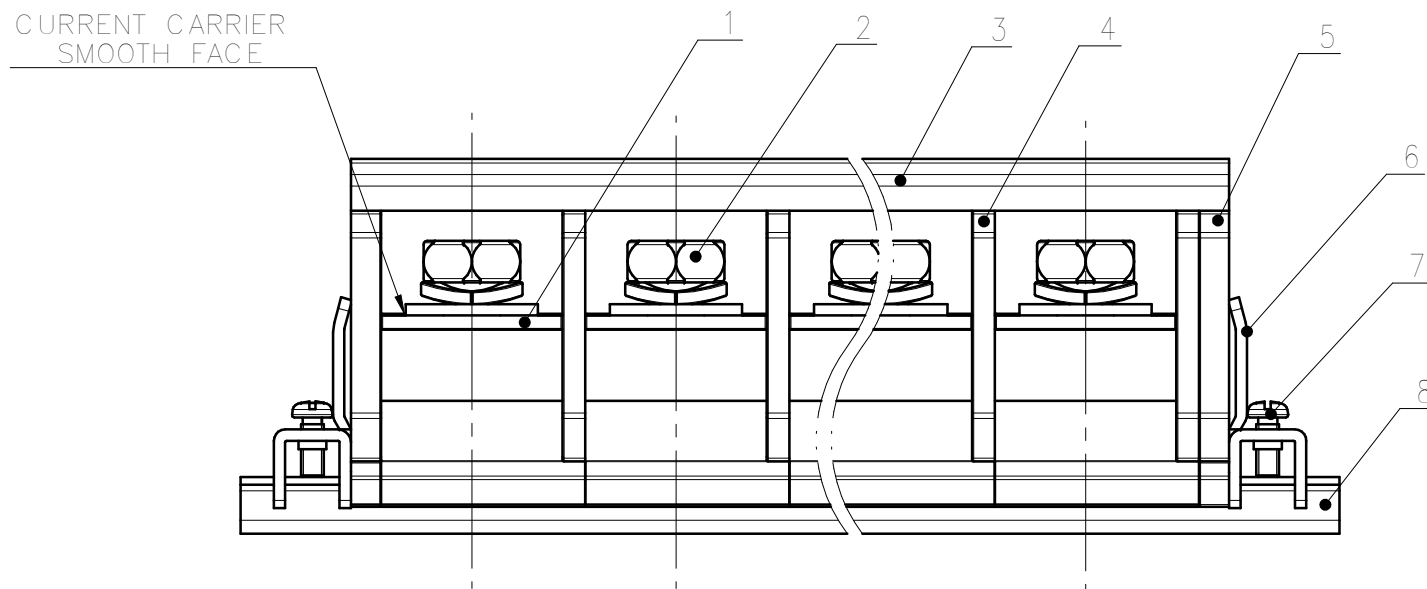

Notes: A&Z(H) in the name means:A(H) and Z(H)

ITEM	NAME OF PART	MATERIAL	NOTES
9	Tag	PVC	UL94V-0
8	Tramroad	Steel	Zn Plated
7	Screw 2	Steel	M3/Zn Plated
6	Fastener	SPCC	Zn Plated
5	Housing2	PC	UL94V-0
4	Housing 1	PC	UL94V-0
3	Cover	PC	UL94V-2
2	Screw 1	Steel	M8/Zn Plated
1	Current carrier	Brass	Ni Plated

DEGSON		MATERIAL: /	SURFACE/COLOR: /	
APPD: 蓝贵凡 2023.10.09		MAT NO./REV: / /00		MAT STATUS: 批量
CHKD: 曹利彬 2023.10.09		NAME: DGR150-XXP-1Y-00A&Z(H)		
DRFT: 汪德荣 2023.10.09		DRAWING NO. 200014956	TYPE CUSTOMER DRAWING	DRAWING STATUS 图纸状态
00	/	正德荣	2023.10.09	SCALE 2:1
REV	ECN	DESCRIPTION	DRFT	DATE
		A3		SHEET 1/1

Transfer or duplication of this document as well as the utilization or communication of its contents are prohibited unless explicit authorization is granted. All rights reserved for patent, utility model, or designs registrations. 复制或再行传播本文件内容, 未经许可, 不得擅自复制或再行传播。 保留所有权利。