

PCB LAYOUT

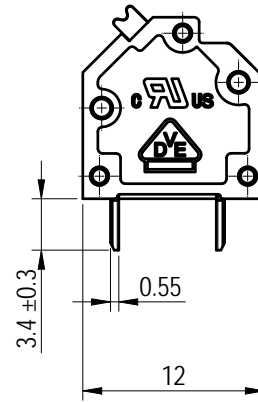
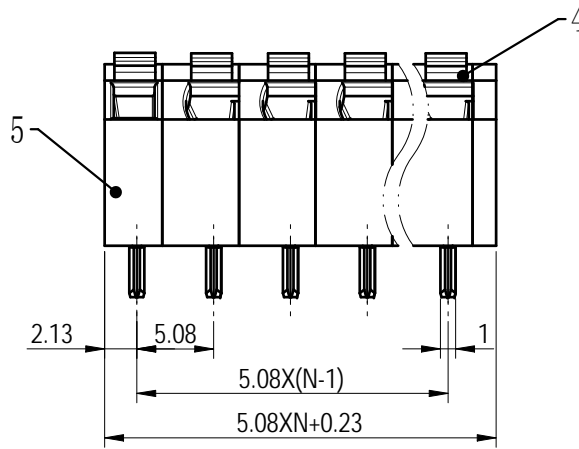
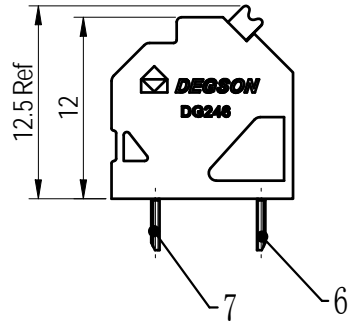
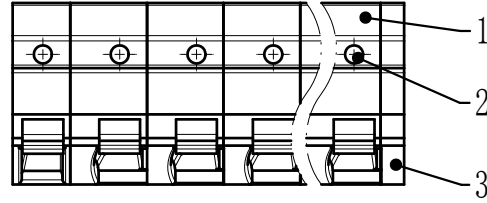
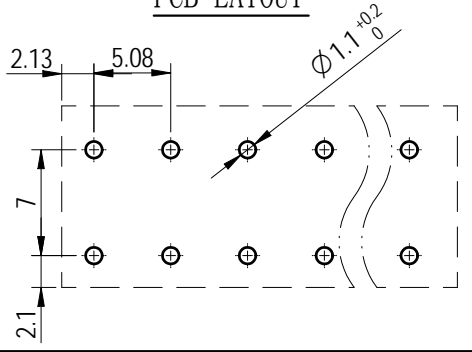

未注公差/General tolerances (mm)													0.1/10	
0 ~ 3	>3 ~ 6	>6 ~ 10	>10 ~ 18	>18 ~ 30	>30 ~ 50	>50 ~ 80	>80 ~ 120	>120 ~ 180	>180 ~ 250	>250 ~ 315	>315 ~ 400	>400 ~ 500		>500
±0.12	±0.18	±0.22	±0.26	±0.31	±0.37	±0.57	±0.80	±0.93	±1.05	±1.15	±1.60	±2.20	±2.50	±2'

ITEM	NAME OF PART	MATERIAL	NOTES
7	Bank Pin Header	Copper alloy	Sn Plated
6	Front Pin Header	Copper alloy	Sn Plated
5	Sid Housing	PA66	UL94V-0
4	Button	POM	UL94HB
3	Cover	PA66	UL94V-0
2	Spring	Stainless steel	/
1	Mid Housing	PA66	UL94V-0

UL 标准/UL Standard:	B	C	D
额定电压/电流/Rated Voltage(V)/Current(A)	300/10	/	300/10
IEC 标准/IEC Standard:			
过压类别/Overvoltage Category/污染等级/Pollution Degree	III/3	III/2	II/2
额定电压/电流/Rated Voltage(V)/Current(A)	250/9	320/9	630/9
额定脉冲电压(KV)/Rate Impulse Voltage(KV)	2.5	2.5	2.5
线径范围(硬线和软线)/Wire Range(rigid and flexible)(AWG/mm ²)	0.2~1.5/26~16		
间距/Pitch(mm)/线数范围/Poles	5.08/N=02~24P		
剥线长度/Stripping length(mm)	10		
使用温度范围/Operating temperature(°C)	-40~+105		
符合RoHS环保要求/Conform to RoHS	Yes		



MATERIAL:	SURFACE/COLOR:
MAT NO./REV: / 01	MAT STATUS: 批量

APPD: 兰春华	2023. 11. 13
CHKD: 张玉华	2023. 11. 10
DRFT: 申玉堂	2023. 11. 10

NAME				
DG246-5.08-XXP-1Y-00Z (H)				

01		IX Add VDE certification mark	申玉堂	2023. 11. 10
REV	ECN	DESCRIPTION	DRFT	DATE

DRFT: 申玉堂	2023. 11. 10	DRAWING NO.	TYPE	DRAWING STATUS	SCALE	SHEET
		200031789	CUSTOMER DRAWING	已发布	2:1	1/1

200031789	CUSTOMER DRAWING	已发布	2:1	1/1
-----------	------------------	-----	-----	-----

Transfer or duplication of this document as well as the utilization or communication of its content are prohibited unless authorized in writing by DEGSON. All rights reserved for patent. 除专利注明情况外，其他内容均受版权保护。未经授权，不得复制或传播。 本公司保留对涉及发明、实用新型及外观设计的所有权利。