

未注公差/General tolerances (mm)													0.1/10	
0	>3	>6	>10	>18	>30	>50	>80	>120	>180	>250	>315	>400		
~3	~6	~10	~18	~30	~50	~80	~120	~180	~250	~315	~400	~500	>500	
±0.12	±0.18	±0.22	±0.26	±0.31	±0.37	±0.57	±0.80	±0.93	±1.05	±1.15	±1.60	±2.20	±2.50	±2'

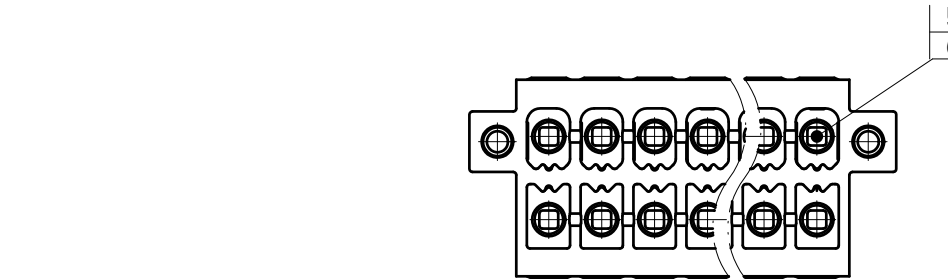
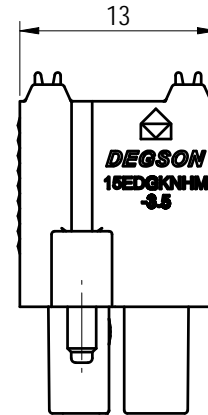
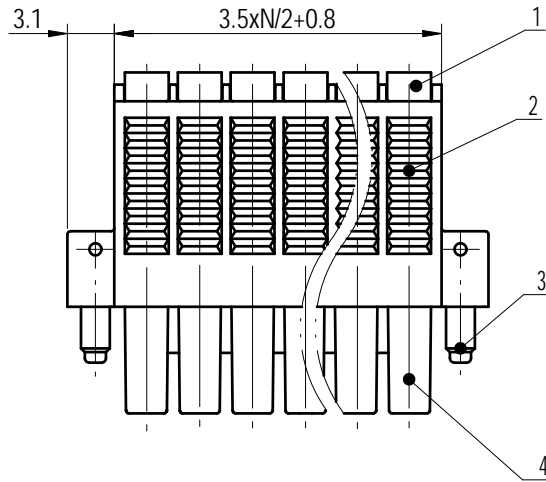
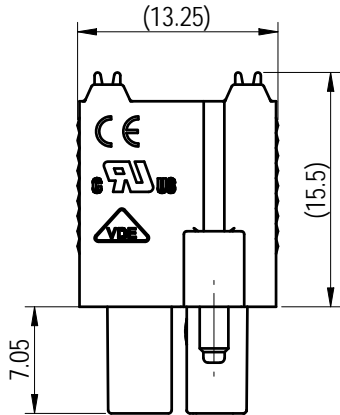
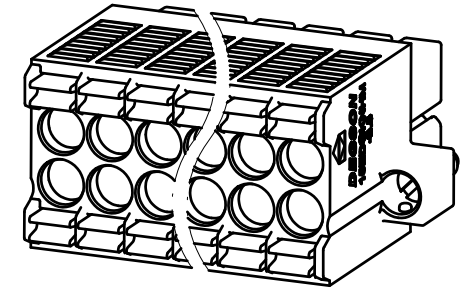
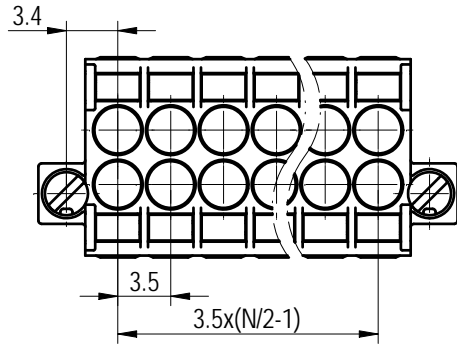

Note:  
The A&Z(H) in the name means: A(H) and Z(H).

ITEM	NAME OF PART	MATERIAL	NOTES
6	Spring	Stainless steel	/
5	Clamp	Copper alloy	Sn Plated
4	Cover	PA66	UL94V-0
3	Screw	Steel	M2/Zn Plated
2	Housing	PA66	UL94V-0
1	Button	POM	UL94HB

UL 标准/UL Standard:	B	C	D
额定电压/电流/Rated Voltage(V)/Current(A)	300/8	50/8	/
IEC 标准/IEC Standard:			
过压类别/Overvoltage Category/污染等级/Pollution Degree	III/3	III/2	II/2
额定电压/电流/Rated Voltage(V)/Current(A)	200/9.5	250/9.5	320/9.5
额定脉冲电压(KV)/Rate Impulse Voltage(KV)	2.5	2.5	2.5
线径范围(硬线和软线)/Wire Range(rigid and flexible)(AWG/mm²)	26~16 / 0.2~1.5		
间距/Pitch(mm)/线数范围/Poles	3.5/N=04~48P		
剥线长度/Stripping length(mm)	10		
使用温度范围/Operating temperature(°C)	-40~-105		
符合RoHS环保要求/Conform to RoHS	Yes		

		MATERIAL:	SURFACE/COLOR:		
MAT NO./REV:		/ 00		MAT STATUS: 批量	
APPD: 兰春华	2022.08.05	NAME			
CHKD: 龚耀志	2022.08.05	15EDGKNHM-3.5-XXP-1Y-00A&Z(H)			
DRFT: 刘强	2022.08.04	DRAWING NO.	TYPE	DRAWING STATUS	SCALE
		200029881	CUSTOMER DRAWING	已发布	2:1
				SHEET	1/1

REV	ECN	DESCRIPTION	DRFT	DATE
00			刘强	2022.08.04

Transfer or duplication of this document as well as the utilization or communication of its contents are prohibited unless explicit authorization is granted. Violations will be liable for compensation. All rights reserved for patent, utility model or design registrations. 除专利等明确授权外, 否则禁止再出、复制、利用。未经允许不得复制或传播。本公司保留全部或部分的专利权、实用新型及外观设计权。