

PCB LAYOUT

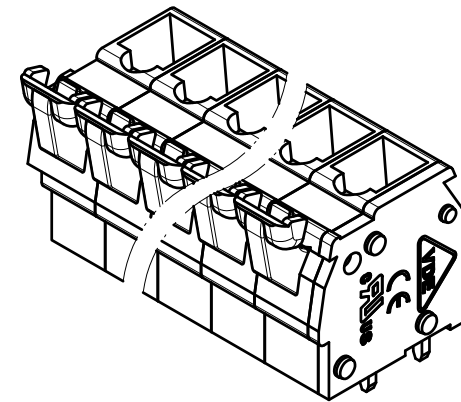
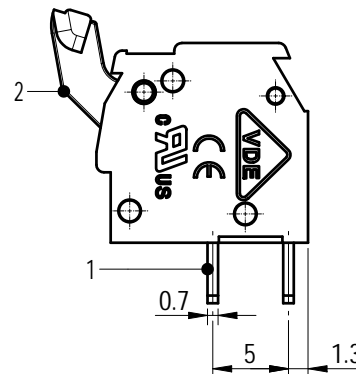
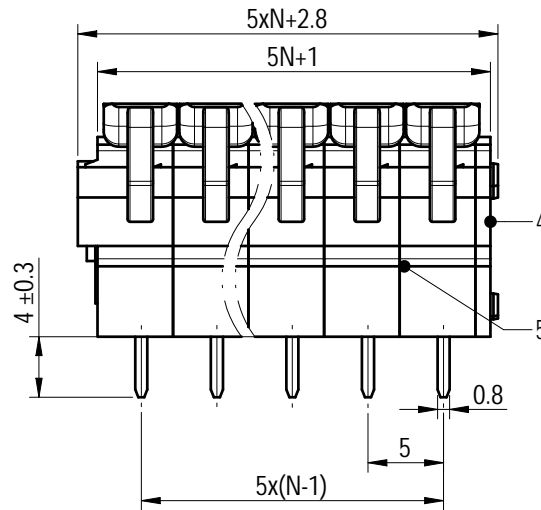
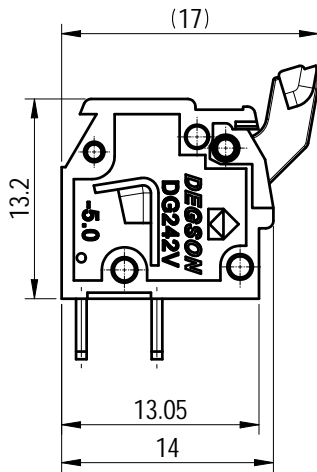
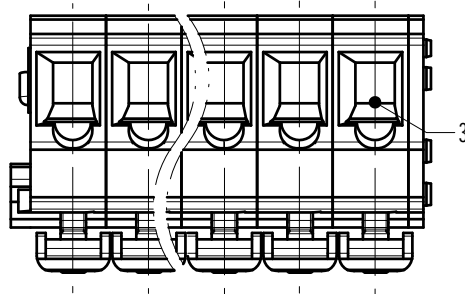
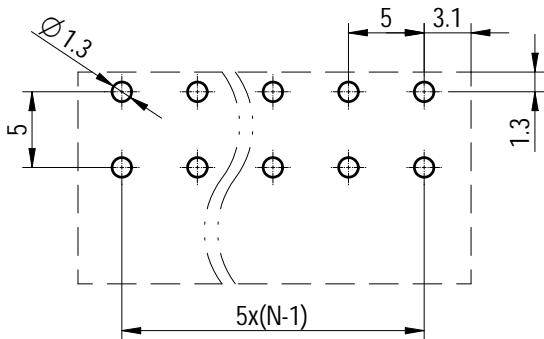

未注公差/General tolerances (mm)													0.1/10
0	>3	>6	>10	>18	>30	>50	>80	>120	>180	>250	>315	>400	
~3	~6	~10	~18	~30	~50	~80	~120	~180	~250	~315	~400	~500	~500
±0.12	±0.18	±0.22	±0.26	±0.31	±0.37	±0.57	±0.80	±0.93	±1.05	±1.15	±1.60	±2.20	±2.50

UL 标准/UL Standard:	B	C	D
额定电压/电流/Rated Voltage(V)/Current(A)	300/15	/	300/10
IEC 标准/IEC Standard:			
过压类别/Overvoltage Category/污染等级/Pollution Degree	III/3	III/2	II/2
额定电压/电流/Rated Voltage(V)/Current(A)	450/17		
工频耐压/Withstanding Voltage (V/1Min)	AC2500		
线径范围(硬线和软线)/Wire Range(rigid and flexible)(AWG/mm²)	28~12/ 0.2~2.5		
间距/Pitch(mm)/线数范围/Poles	5.0/N=01~32P		
剥线长度/Stripping length(mm)	5~6		
使用温度范围/Operating temperature(°C)	-40~+105		
符合RoHS环保要求/Conform to RoHS	Yes		

Note:
The A&Z(H) in the name means: A(H) and Z(H).

ITEM	NAME OF PART	MATERIAL	NOTES
5	Housing	PA66	UL94V-0
4	Cover	PA66	UL94V-0
3	Spring	Stainless steel	/
2	Button	POM	UL94HB
1	Pin header	Copper alloy	Sn Plated

		MATERIAL: /	SURFACE/COLOR: /		
APPD: 兰春华 2022.09.26		MAT NO./REV: - / 00	MAT STATUS: 批量		
CHKD: 陈招 2022.09.26		NAME			
DRFT: 柳学龙 2022.09.26		DG242V-5.0-XXP-1Y-00A&Z(H)			
DRAWING NO.	TYPE	DRAWING STATUS	SCALE	SHEET	
200025297	CUSTOMER DRAWING	已发布	2:1	1/1	

REV	ECN	DESCRIPTION	DRFT	DATE
00			柳学龙	2022.09.26

Transfer or duplication of this document as well as the utilization or communication of its contents are prohibited unless authorized in writing by DEGSON. All rights reserved for patent, utility model or design registrations. 除专利权明确标注外, 其他内容均受法律保护。 未经授权, 禁止复制或传播。 未经书面许可, 不得复制或传播。 未经授权, 禁止复制或传播。