

未注公差/General tolerances (mm)												0.1/10		
0 ~ 3	>3 ~ 6	>6 ~ 10	>10 ~ 18	>18 ~ 30	>30 ~ 50	>50 ~ 80	>80 ~ 120	>120 ~ 180	>180 ~ 250	>250 ~ 315	>315 ~ 400		>400 ~ 500	>500
±0.12	±0.18	±0.22	±0.26	±0.31	±0.37	±0.57	±0.80	±0.93	±1.05	±1.15	±1.60	±2.20	±2.50	±2'

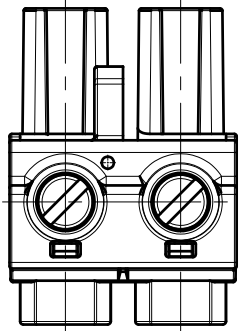

02P

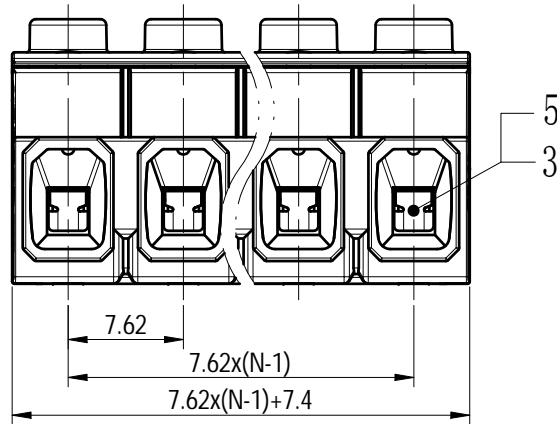
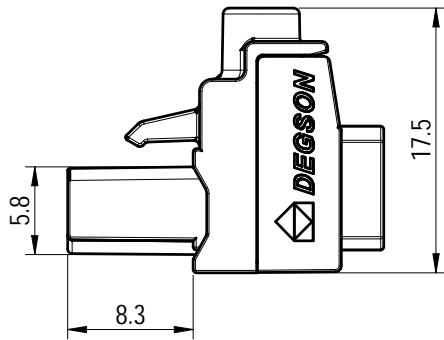
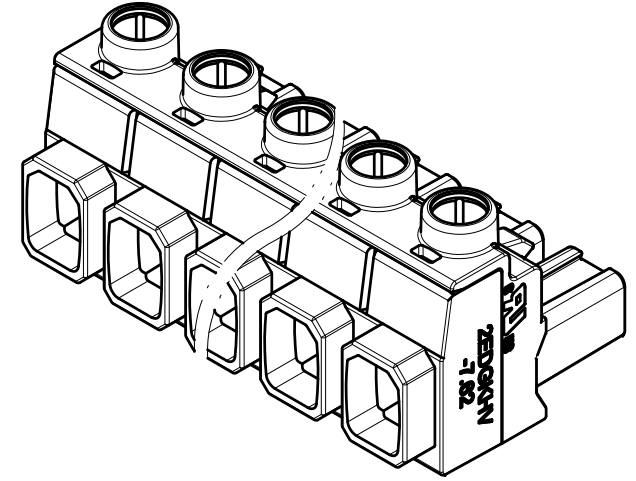
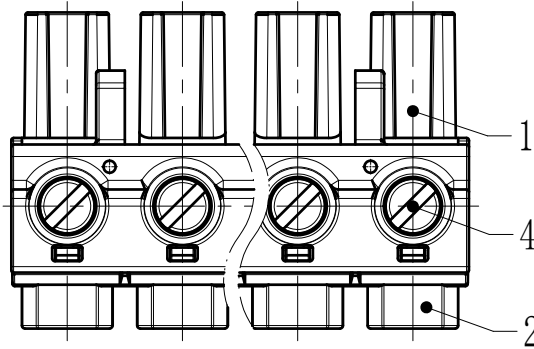

Certification mark is allowed on one of both sides

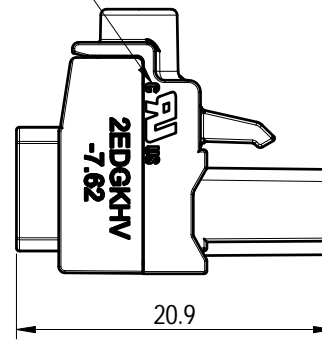

Note:
The A&Z(H) in the name means: A(H) and Z(H).

ITEM	NAME OF PART	MATERIAL	NOTES
5	Cage	Copper alloy	M3/Ni Plated
4	Screw	Steel	M3/Zn Plated
3	Clamp	Copper alloy	Sn Plated
2	Cover	PA66	UL94V-0
1	Housing	PA66	UL94V-0

ITEM	NAME OF PART	MATERIAL	NOTES	
UL 标准/UL Standard:		B	C	D
额定电压/电流/Rated Voltage(V)/Current(A)		600/20	600/20	/
IEC 标准/IEC Standard:				
过压类别/Ovenvoltage Category/污染等级/Pollution Degree		III/3	III/2	II/2
额定电压/电流/Rated Voltage(V)/Current(A)		1000/16	1000/16	1000/16
额定脉冲电压(KV)/Rate Impulse Voltage(KV)		8	8	6
螺丝扭矩/Torque Tightening(N·m/Lb.in)		M3, 0.6/5.5		
线径范围(硬线和软线)/Wire Range (rigid and flexible)(AWG/mm²)		30~12 / 0.2~2.5		
间距/Pitch(mm)/线数范围/Poles		7.62/N=02~12P		
剥线长度/Stripping length(mm)		7~8		
使用温度范围/Operating temperature(°C)		-40~+105		
符合RoHS环保要求/Conform to RoHS		Yes		

		MATERIAL:	SURFACE:
		MAT NO./REV:	MAT STATUS: 批量
APPD: 兰春华	2023.02.14	NAME	
CHKD: 龚耀志	2023.02.09	2EDGKHV-7.62-XXP-1Y-00A&Z(H)	
DRFT: 朱岳鹏	2023.02.09	DRAWING NO.	TYPE
		200040311	
REV	ECN	DESCRIPTION	DRAWING STATUS
00			已发布
			SCALE
			2:1
			SHEET
			1/1

Transfer or duplication of this document as well as the utilization or communication of its contents are prohibited unless express consent is obtained from DEGSON. All rights reserved for patent, utility model or design registrations. 非经书面授权, 否则禁止转让、复制、利用、交流本文档的内容。侵犯者将负法律责任。 侵犯者将负法律责任。 侵权型和外观专利的所有权利。