

PCB LAYOUT

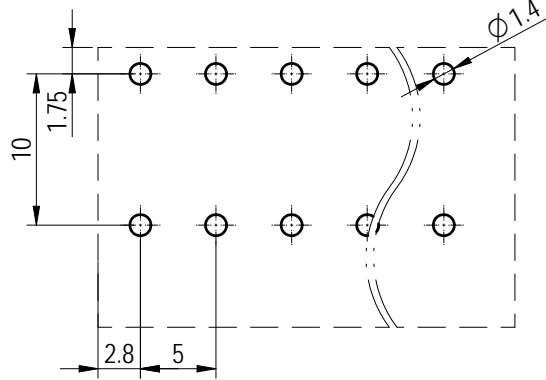

公差/General tolerances (mm)												0.1/10			
0 ~ 3	>3 ~ 6	>6 ~ 10	>10 ~ 18	>18 ~ 30	>30 ~ 50	>50 ~ 80	>80 ~ 120	>120 ~ 180	>180 ~ 250	>250 ~ 315	>315 ~ 400	>400 ~ 500	>500	0.1/10	0.1/10
±0.12	±0.18	±0.22	±0.26	±0.31	±0.37	±0.57	±0.80	±0.93	±1.05	±1.15	±1.60	±2.20	±2.50	±2'	±2'

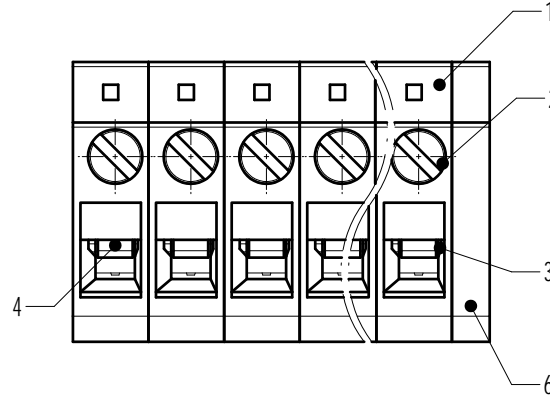

UL 标准/UL Standard:		B	C	D
额定电压/电流/Rated Voltage(V)/Current(A)		300/20	/	300/10
IEC 标准/IEC Standard:				
过压类别/Overvoltage Category/污染等级/Pollution Degree		III/3	III/2	II/2
额定电压/电流/Rated Voltage(V)/Current(A)		/	250/24	/
工频耐压/Withstanding voltage(V/1Min)		AC2000		
螺丝扭矩/Torque Tightening(N·m/Lb.in)		M2.5: 0.4/3.54		
线径范围(硬线和软线)/Wire Range(rigid and flexible)(AWG/mm²)		30~12 / 0.5~2.5		
间距/Pitch(mm)/线数范围/Poles		5.0/N=01~24P		
剥线长度/Stripping length(mm)		12~13		
使用温度范围/Operating temperature(°C)		-40~+105		
符合RoHS环保要求/Conform to RoHS		Yes		
6	Cover	PA66	UL94V-0	
5	Pin header	Copper	Sn Plated	
4	Block	Steel	Zn Plated	
3	Cage	Steel	M2.5/Zn Plated	
2	Screw	Steel	M2.5/Zn Plated	
1	Housing	PA66	UL94V-0	
ITEM	NAME OF PART	MATERIAL	NOTES	

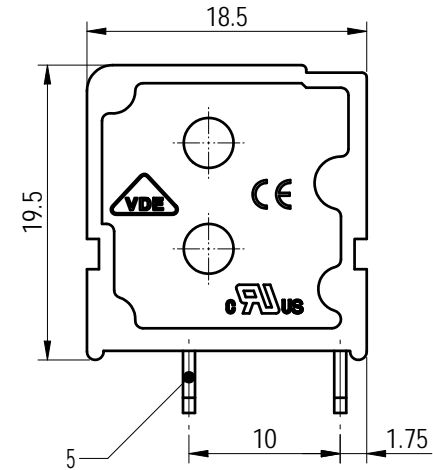
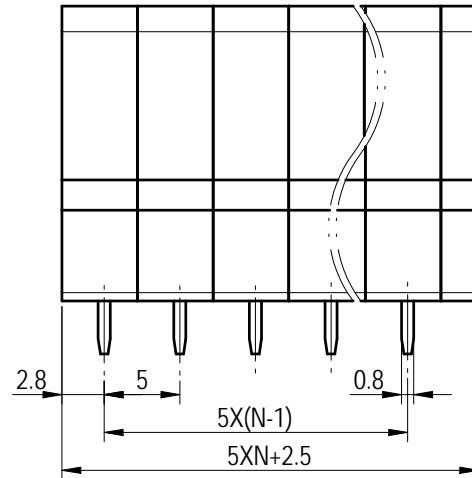
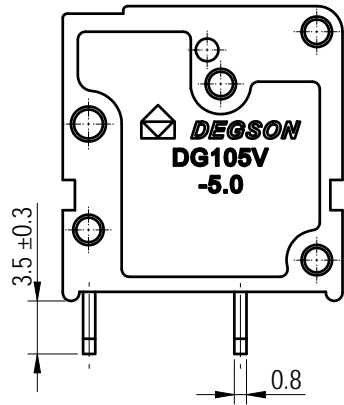

<b>DEGSON</b>		MATERIAL:	SURFACE/COLOR:		
		MAT NO./REV:	MAT STATUS: 批量		
APPD: 兰春华	2024.11.25	NAME			
CHKD: 龚耀志	2024.11.25	DG105V-5.0-XXP-1Y-10A&Z(H)			
DRFT: 陈兰馨	2024.11.25	DRAWING NO.	TYPE	DRAWING STATUS	SCALE
		200096340	CUSTOMER DRAWING	已发布	2:1
				SHEET	1/1

REV	ECN	DESCRIPTION	DRFT	DATE
00			陈兰馨	2024.11.25

Transfer or duplication of this document as well as the utilization or communication of its contents are prohibited unless expressly permitted in writing by DEGSON. All rights reserved for patent, utility model or design registrations. 除特别说明外, 未经许可, 不得复制或传播。 保留所有权利, 未经许可, 不得复制或传播。 除特别说明外, 未经许可, 不得复制或传播。 保留所有权利, 未经许可, 不得复制或传播。