

未注公差/General tolerances (mm)												0.1/10		
0 ~ 3	>3 ~ 6	>6 ~ 10	>10 ~ 18	>18 ~ 30	>30 ~ 50	>50 ~ 80	>80 ~ 120	>120 ~ 180	>180 ~ 250	>250 ~ 315	>315 ~ 400		>400 ~ 500	>500
±0.12	±0.18	±0.22	±0.26	±0.31	±0.37	±0.57	±0.80	±0.93	±1.05	±1.15	±1.60	±2.20	±2.50	±2'

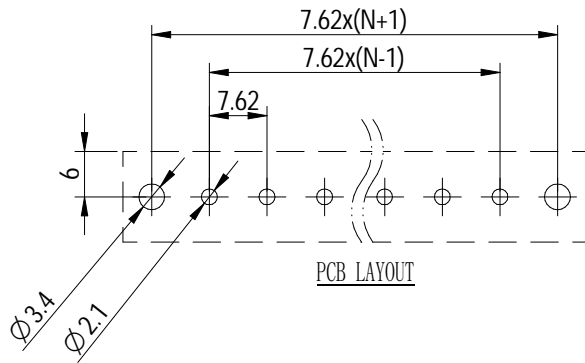
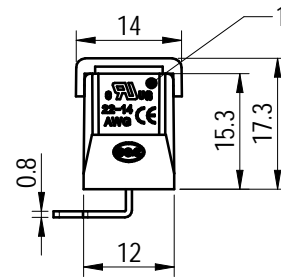
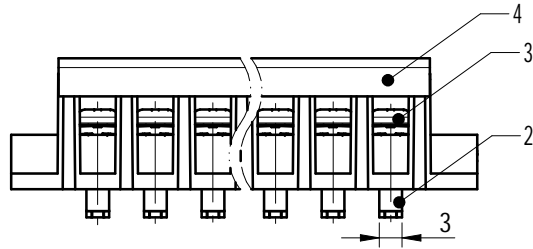
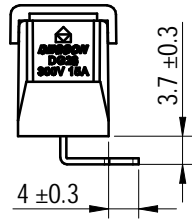
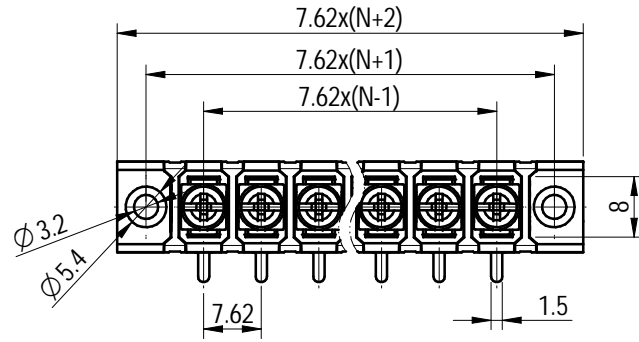

Note: The A&Z (H) in the name means :A(H) and Z(H)

ITEM	NAME OF PART	MATERIAL	NOTES
4	Cover	PC	/
3	Screw	Steel	M3/Ni plated
2	Pin header	Brass	M3/Sn plated
1	Housing	PA66+25%GF	UL94V-0
UL 标准/UL Standard:			B C D
额定电压/电流/Rated Voltage(V)/Current(A)			300/15 / 300/10
螺丝扭矩/Torque Tightening(N·m/Lb.in)			M3, 0.5/4.43
线径范围(硬线和软线)/Wire Range(rigid and flexible)(AWG/mm²)			22~14 / 0.32~2.1
间距/Pitch(mm)/线数范围/Poles			7.62,N=02~24P
使用温度范围/Operating temperature(°C)			-40~+105
符合RoHS环保要求/Conform to RoHS			Yes

		MATERIAL: /	SURFACE/COLOR: /		
APPD: 核准人		MAT NO./REV: /	MAT STATUS: /		
CHKD: 审核人		NAME			
DRFT: 设计人		DG28R-A-XXP-1Y-00A&Z (H)			
00	/	/	/	/	/
REV	ECN	DESCRIPTION	DRFT	DATE	
DRAWING NO. 200321679		TYPE CUSTOMER DRAWING		DRAWING STATUS /	SCALE 1:1 SHEET 1/1

Transfer or duplication of this document as well as the utilization or communication of its contents are prohibited unless authorized in general. All rights reserved for patent, utility model or design registrations. 除专利、实用新型、外观设计、发明专利、软件著作权、集成电路布图设计专有权、商业秘密和程序等权利外，本公司保留对涉及发明、实用新型、外观设计、集成电路布图设计等权利的所有权。