

公差/General tolerances (mm)													0.1/10	
0	>3	>6	>10	>18	>30	>50	>80	>120	>180	>250	>315	>400		
~3	~6	~10	~18	~30	~50	~80	~120	~180	~250	~315	~400	~500	>500	
±0.12	±0.18	±0.22	±0.26	±0.31	±0.37	±0.57	±0.80	±0.93	±1.05	±1.15	±1.60	±2.20	±2.50	±2'

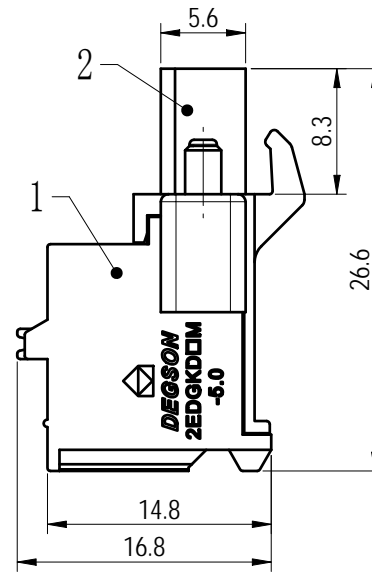
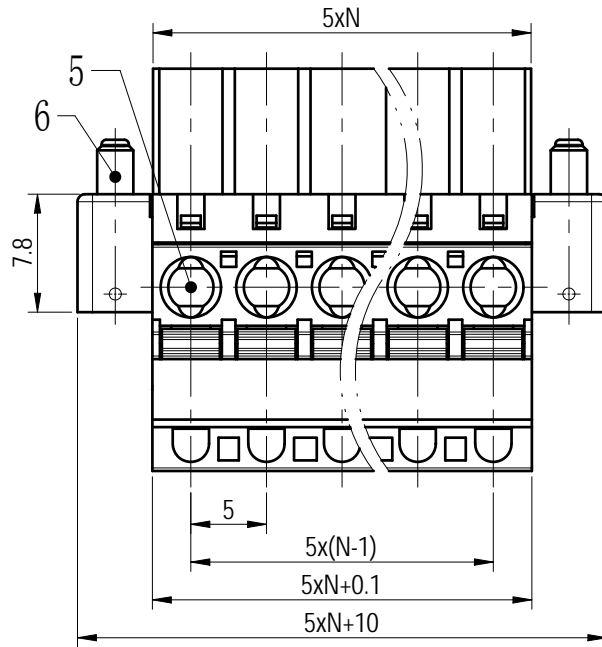
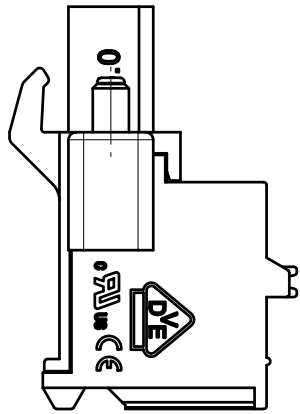
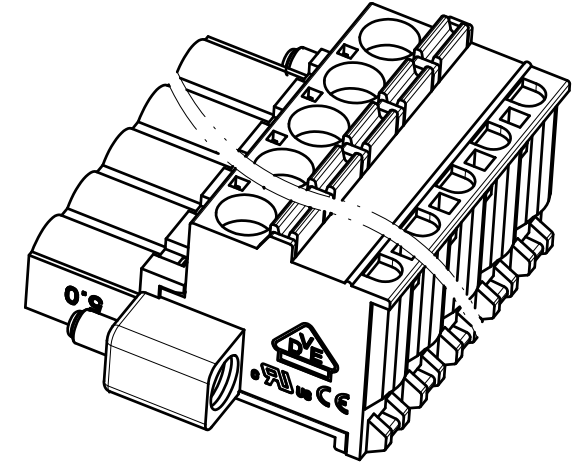
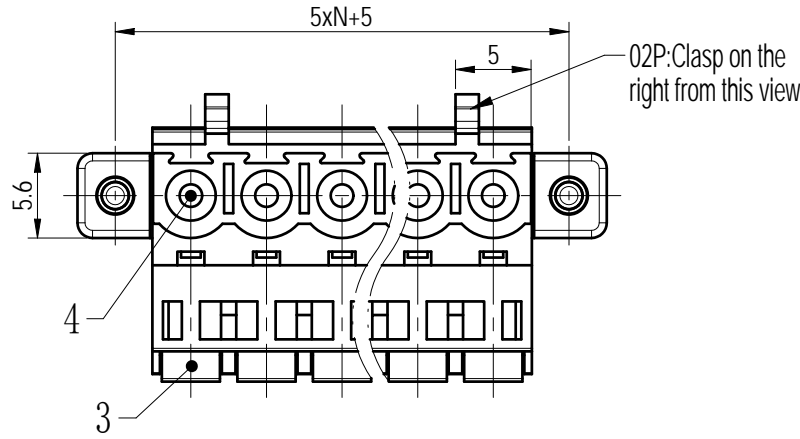

Note:
The A&Z(H) in the name means: A(H) and Z(H).

ITEM	NAME OF PART	MATERIAL	NOTES
6	Screw	Steel	M2.5/Zn Plated
5	Spring	Stainless Steel	/
4	Clamp	Copper alloy	Sn Plated
3	Button	PA66	UL94V-0
2	Cover	PA66	UL94V-0
1	Housing	PA66	UL94V-0

UL 标准/UL Standard:	B	C	D
额定电压/电流/Rated Voltage(V)/Current(A)	300/10	/	300/10
IEC 标准/IEC Standard:			
过压类别/Ovenvoltage Category/污染等级/Pollution Degree	III/3	III/2	II/2
额定电压/电流/Rated Voltage(V)/Current(A)	/	320/20	/
额定脉冲电压(KV)/Rate Impulse Voltage(KV)	/	4.0	/
线径范围(硬线和软线)/Wire Range (rigid and flexible)(AWG/mm²)	26~12 / 0.2~2.5		
间距/Pitch(mm)/线数范围/Poles	5.0/N=02~24P		
剥线长度/Stripping length(mm)	10		
使用温度范围/Operating temperature(°C)	-40~+105		
符合RoHS环保要求/Conform to RoHS	Yes		

		MATERIAL:	SURFACE/COLOR:		
APPD: 兰春华 2023.01.04		MAT NO./REV: - / 00	MAT STATUS: 批量		
CHKD: 陈招 2023.01.04		NAME: 2EDGKDBM-5.0-XXP-1Y-00A&Z(H)			
DRFT: 朱岳鹏 2023.01.03		DRAWING NO. 200020155	TYPE: CUSTOMER DRAWING	DRAWING STATUS: 已发布	SHEET: 1/1

REV	ECN	DESCRIPTION	DRFT	DATE
00			朱岳鹏	2023.01.03

Transfer or duplication of this document as well as the utilization or communication of its content are prohibited unless authorized in writing. All rights reserved for patent, utility model or design registrations. 除专利、实用新型、外观设计、软件著作权等权利外，保留所有权利。未经许可，不得复制或传播。