

未注公差/General tolerances (mm)													0.1/10
0	>3	>6	>10	>18	>30	>50	>80	>120	>180	>250	>315	>400	
~3	~6	~10	~18	~30	~50	~80	~120	~180	~250	~315	~400	~500	>500
±0.12	±0.18	±0.22	±0.26	±0.31	±0.37	±0.57	±0.80	±0.93	±1.05	±1.15	±1.60	±2.20	±2.50

O2P: Clasp on the left from this view

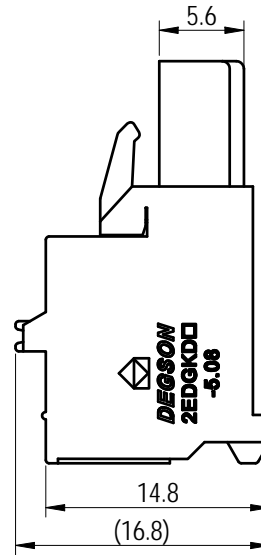
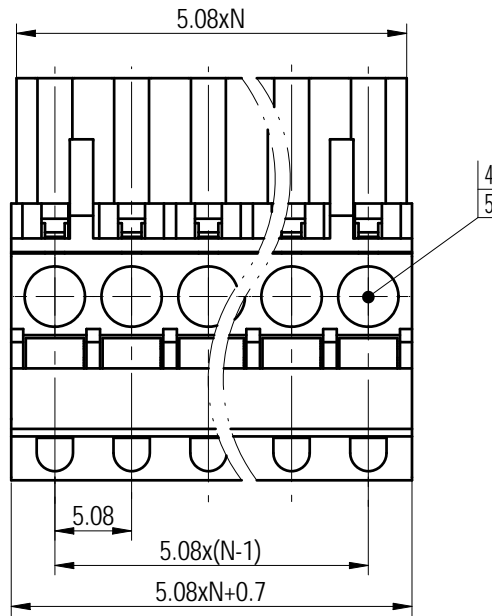
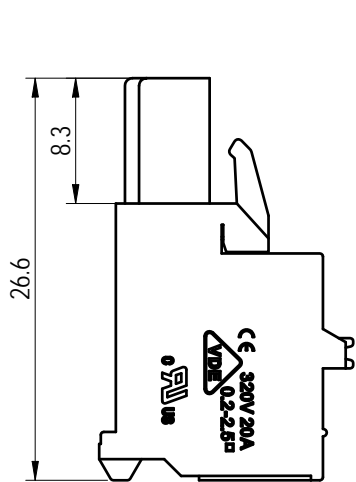
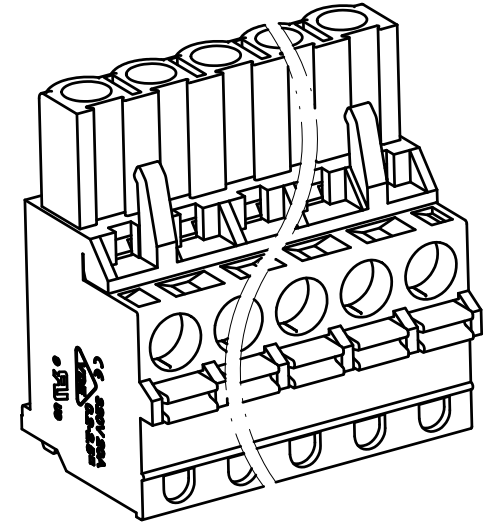
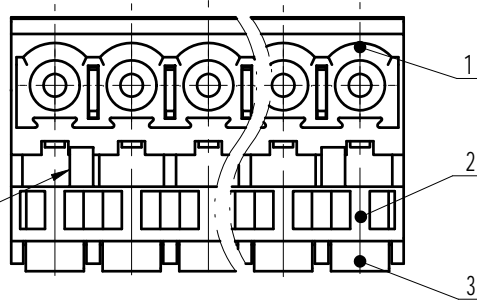

Note:
The A&Z(H) in the name means: A(H) and Z(H).

ITEM	NAME OF PART	MATERIAL	NOTES
5	Spring	Stainless steel	/
4	Clamp	Copper alloy	Sn Plated
3	Button	PA66	UL94V-0
2	Housing	PA66	UL94V-0
1	Cover	PA66	UL94V-0

UL 标准/UL Standard:	B	C	D
额定电压/电流/Rated Voltage(V)/Current(A)	300/10	/	300/10
IEC 标准/IEC Standard:			
过压类别/Overvoltage Category/污染等级/Pollution Degree	III/3	III/2	II/2
额定电压/电流/Rated Voltage(V)/Current(A)	/	320/20	/
额定脉冲电压(KV)/Rate Impulse Voltage(KV)	/	4	/
螺丝扭矩/Torque Tightening(N·m/Lb.in)	/		
线径范围(硬线和软线)/Wire Range (rigid and flexible)(AWG/mm ²)	26~12/ 0.2~2.5		
间距/Pitch(mm)/线数范围/Poles	5.08/N=02~18P		
剥线长度/Stripping length(mm)	9~10		
使用温度范围/Operating temperature(°C)	-40~+105		
符合RoHS环保要求/Conform to RoHS	Yes		
标准颜色编号/Standard color number: PANTONE / RAL	/		



APPD: 兰春华	2022.11.08
CHKD: 龚耀志	2022.11.08
DRFT: 刘强	2022.11.07

MATERIAL:	SURFACE/COLOR:		
MAT NO./REV:	/ 00	MAT STATUS: 批量	
NAME	2EDGKDA-5.08-XXP-1Y-00A&Z(H)		
DRAWING NO.	TYPE	DRAWING STATUS	SCALE
200030428	CUSTOMER DRAWING	已发布	2:1
SHEET		1/1	

00			刘强	2022.11.07
REV	ECN	DESCRIPTION	DRFT	DATE

Transfer or duplication of this document as well as the utilization or communication of its contents are prohibited unless explicit authorization is granted. Violations will be liable for compensation. All rights reserved for patent, utility model or design registrations. 除非得到明确授权，否则禁止复制或传播。未经许可擅自复制或传播，侵权者将承担法律责任。本公司保留对设计专利的所有权利。