

02P

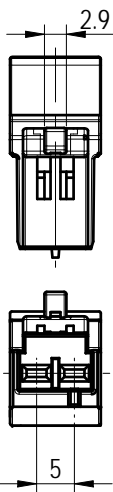

03P

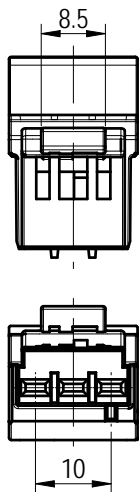

04P

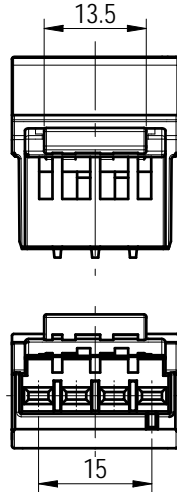

未注公差/General tolerances (mm)

0	>3	>6	>10	>18	>30	>50	>80	>120	>180	>250	>315	>400	>500	0.1/10 ±2'
~3	~6	~10	~18	~30	~50	~80	~120	~180	~250	~315	~400	~500		
±0.12	±0.18	±0.22	±0.26	±0.31	±0.37	±0.57	±0.80	±0.93	±1.05	±1.15	±1.60	±2.20	±2.50	

UL 标准/UL Standard:

额定电压/电流/Rated Voltage(V)/Current(A)

IEC 标准/IEC Standard:

过压类别/Overtoltage Category/污染等级/Pollution Degree

额定电压/电流/Rated Voltage(V)/Current(A)

额定脉冲电压(KV)/Rate Impulse Voltage(KV)

螺丝扭矩/Torque Tightening(N·m/Lb.in)

线径范围(硬线和软线)/Wire Range(rigid and flexible)(AWG/mm²)

间距/Pitch(mm)/线数范围/Poles

剥线长度/Stripping length(mm)

使用温度范围/Operating temperature(°C)

符合RoHS环保要求/Conform to RoHS

4	Spring	Stainless steel	/
3	Clamp	Copper alloy	Au Plated Area
2	Cover	PA66+GF	UL94V-0
1	Housing	PA66+GF	UL94V-0
ITEM	NAME OF PART	MATERIAL	NOTES

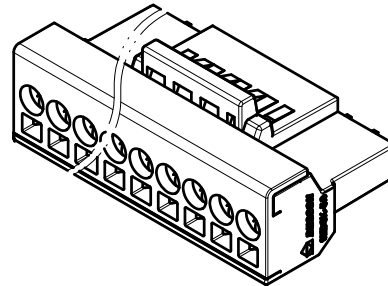
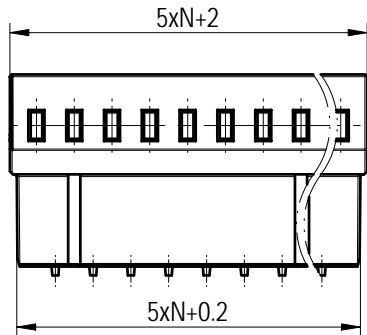

Note:
The A&Z(H) in the name means:A(H) and Z(H).

Poles	Dim. X (mm)	Dim. Y (mm)
02P	2.9	-
03P	8.5	-
04P	13.5	-
05P	8.5	10
06P	13.5	15
07P	18.5	20
08P	13.5	25
09P	18.5	30
10P	23.5	35
11P	18.5	40
12P	23.5	45
13P	18.5	50
14P	23.5	55

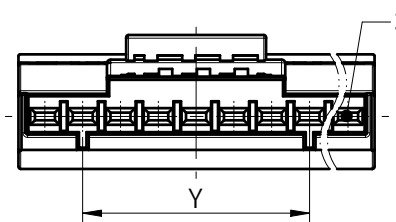
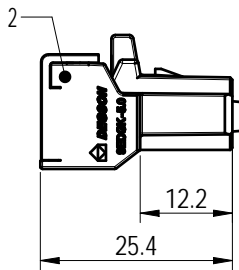
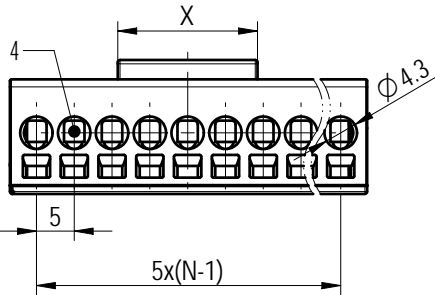
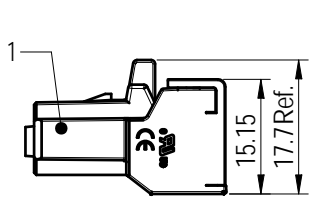

MATERIAL: SURFACE/COLOR:
MAT NO./REV: - / 00 MAT STATUS: 批量

APPD: 兰春华 2023.03.17
CHKD: 龚耀志 2023.03.17

NAME: 9EDGK-5.0-XXP-1Y-00A&Z(H)

DRFT: 周锡锦 2023.03.17

DRAWING NO. 200029806 TYPE CUSTOMER DRAWING DRAWING STATUS 已发布 SCALE 1:1 SHEET 1/1

00			周锡锦	2023.03.17
REV	ECN	DESCRIPTION	DRFT	DATE

Transfer or duplication of this document as well as the utilization or communication of its contents are prohibited unless authorized in advance. Weights and dimensions are for reference only. All rights reserved for patent. 除专利注明情况外，其他部分均不作为侵权。未经许可，不得复制或传播。如有侵权，必究。 本公司保留对产品及零件、规格、材料、工艺等文件的修改权，恕不另行通知。