

未注公差/General tolerances (mm)													0.1/10	
0 ~ 3	>3 ~ 6	>6 ~ 10	>10 ~ 18	>18 ~ 30	>30 ~ 50	>50 ~ 80	>80 ~ 120	>120 ~ 180	>180 ~ 250	>250 ~ 315	>315 ~ 400	>400 ~ 500		>500
±0.12	±0.18	±0.22	±0.26	±0.31	±0.37	±0.57	±0.80	±0.93	±1.05	±1.15	±1.60	±2.20	±2.50	±2'

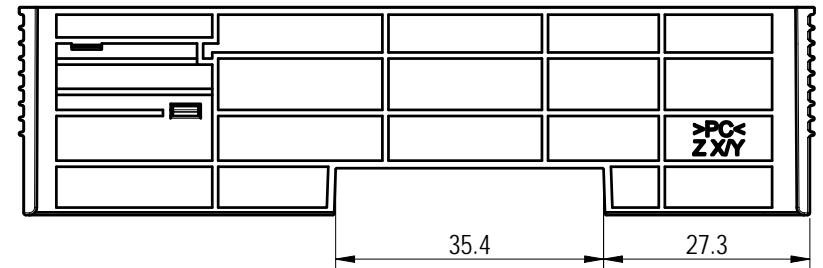
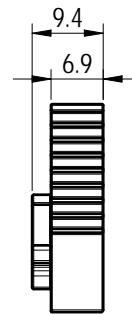
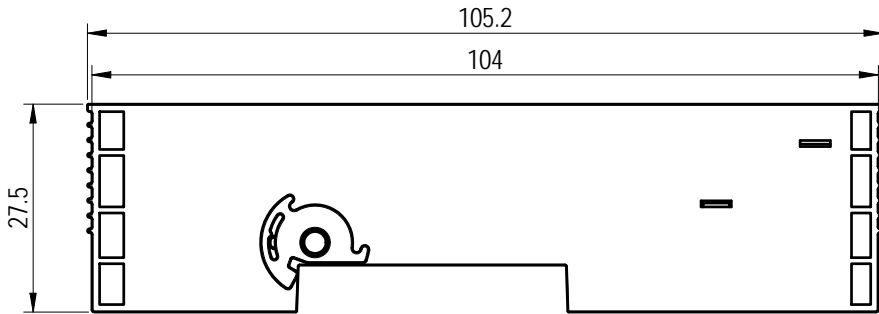
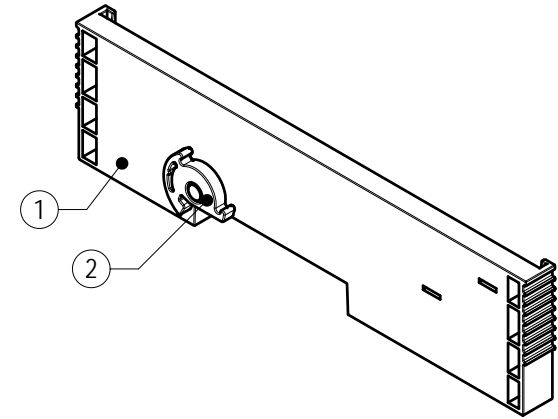
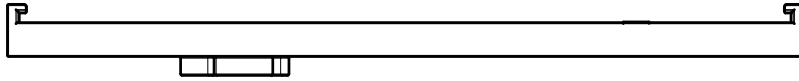

间距/Pitch(mm)/线数范围/Poles			N=01P
使用温度范围/Operating temperature(°C)			-40~+110
符合RoHS环保要求/Conform to RoHS			Yes
标准颜色编号/Standard color number: PANTONE / RAL			7
1	Housing	PC	UL94V-2
1	DF750-Handlebar-Housing	PA66	UL94V-0
ITEM	NAME OF PART	MATERIAL	NOTES

		MATERIAL:		SURFACE/COLOR:	
		MAT NO./REV: 30060000178-1 / 00		MAT STATUS: 样品	
APPD: 李根芳	2023.04.18	NAME			
CHKD: 马恩升	2023.04.18	DF700-T-C1-00Z (H)			
DRFT: 霍恩榕	2023.04.18				
DRAWING NO.	TYPE	DRAWING STATUS	SCALE	SHEET	
200178520	CUSTOMER DRAWING	work	2:1	1/1	

00	/	NEW DRAWING	霍恩榕	2023.04.18
REV	ECN	DESCRIPTION	DRFT	DATE

Transfer or duplication of this document as well as the utilization or communication of its contents are prohibited unless authorized in writing by the copyright owner. All rights reserved for patent, utility model or design registrations. 除专利等明确标注外, 否则禁止转让、复制、引用、交流等文件的所有权。 未经权利人许可, 擅自复制或传播文件, 侵犯权利人合法权益。 保留所有权利, 侵权必究。