

未注公差/General tolerances (mm)													0.1/10 ±2'
0	>3	>6	>10	>18	>30	>50	>80	>120	>180	>250	>315	>400	
~3	~6	~10	~18	~30	~50	~80	~120	~180	~250	~315	~400	~500	>500
±0.12	±0.18	±0.22	±0.26	±0.31	±0.37	±0.57	±0.80	±0.93	±1.05	±1.15	±1.60	±2.20	±2.50

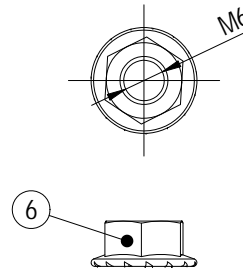

BS6 N-YY  
YY(Color): GY(Grey)、RD(Red)、BU(Blue)  
OG(Orange)、FE(Yellow and Black)

面板安装示意图/Panel installation diagram

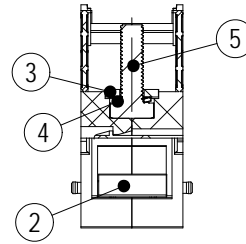
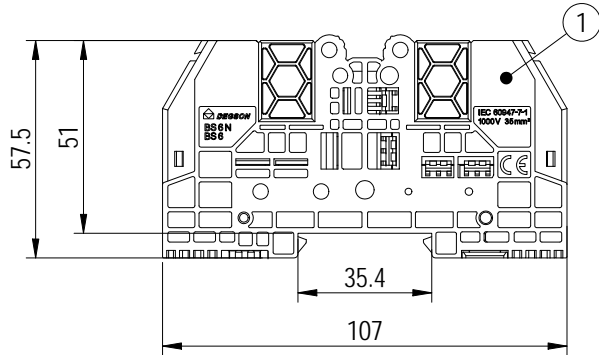
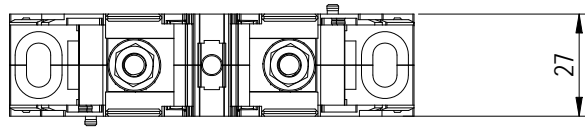
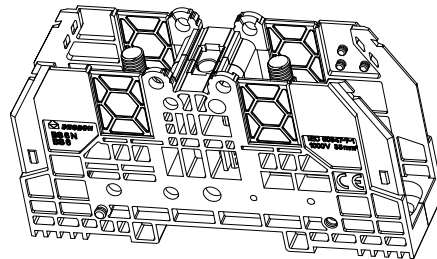
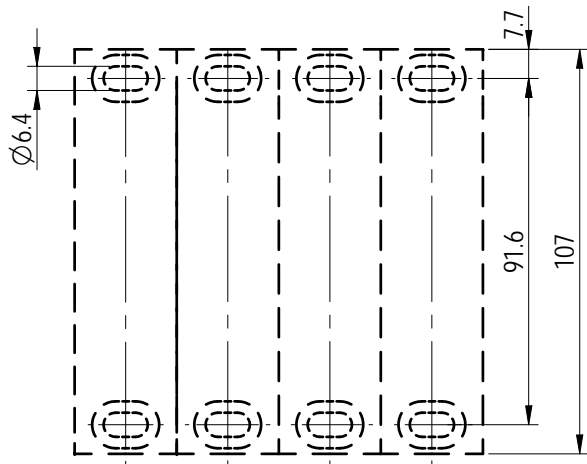

ITEM	NAME OF PART	MATERIAL	NOTES
6	Nut	Steel	M6/Zn Plated
5	Bolt	Steel	M6/Zn Plated
4	Lock Washer	Steel	M6/Zn Plated
3	Current carrier	Copper	Sn Plated
2	Mounting Bar	PA66	UL94V-0
1	Housing	PA66	UL94V-0

UL 标准/UL Standard:	B	C	D
额定电压/电流/Rated Voltage(V)/Current(A)	600/115	/	/
IEC 标准/IEC Standard:			
过压类别/Overvoltage Category/污染等级/Pollution Degree	III/3	III/2	II/2
额定电压/电流/Rated Voltage(V)/Current(A)	1000/125	/	/
额定脉冲电压(KV)/Rate Impulse Voltage(KV)	8	/	/
螺栓扭矩/Torque Tightening(N·m/Lb.in)	M6, 3-6/33.9-67.4		
固定螺钉规格/Fixing Screw Specifications	M6		
线径范围(硬线和软线)/Wire Range(rigid and flexible)(AWG/mm²)	16-2 / 2.5-35		
间距/Pitch(mm)/线数范围/Poles	27/N=01P		
剥线长度/Stripping length(mm)	Depends on Cold pressing		
使用温度范围/Operating temperature(°C)	-40~+105		
符合RoHS环保要求/Conform to RoHS	Yes		

<b>DEGSON</b>		MATERIAL:	SURFACE/COLOR:
APPD: Li GL	2023.03.14	MAT NO./REV:	/
CHKD: Ma EK	2023.03.14	MAT STATUS:	批量
DRFT: Zheng QG	2023.03.14	NAME	BS6 N-YY
DRAWING NO.	200098793	TYPE	CUSTOMER DRAWING
DRAWING STATUS	已发布	SCALE	2:1
SHEET	1/1		

REV	ECN	DESCRIPTION	DRFT	DATE
00		NEW DRAWING	Zheng QG	2023.03.14

Transfer or duplication of this document as well as the utilization or communication of its contents are prohibited unless authorized in writing by DEGSON. All rights reserved for patent. Utility model or design registrations. 除专利等明确标注外，其他内容均受法律保护。未经授权，不得复制或传播。所有权利保留。公司保留对涉及发明、实用新型和外观设计的所有权利。