

未注公差/General tolerances(mm)											0.1/10 ±2'		
0	>3	>6	>10	>18	>30	>50	>80	>120	>180	>250		>315	>400
±0.12	±0.18	±0.22	±0.26	±0.31	±0.37	±0.57	±0.80	±0.93	±1.05	±1.15	±1.60	±2.20	±2.50

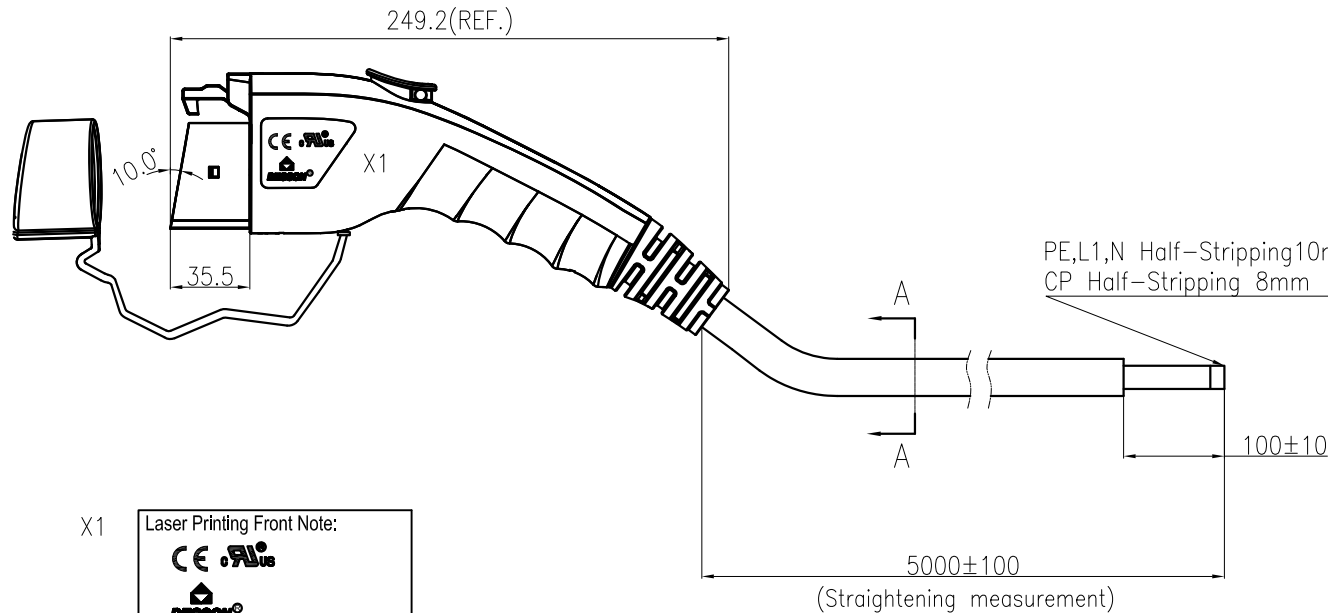

Wiring diagram

- L1 10AWG Brown
- N 10AWG Blue
- PE 10AWG Yellow/Green
- CS
- CP 18AWG Red

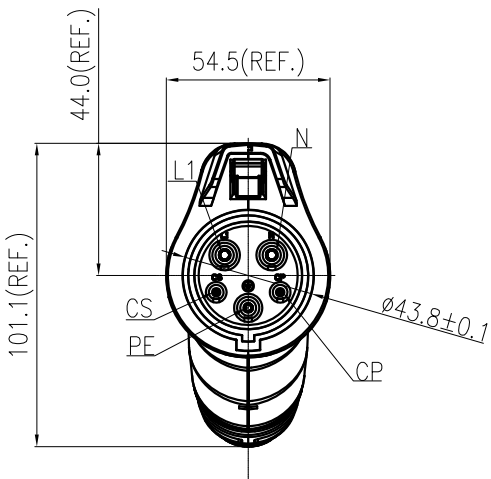
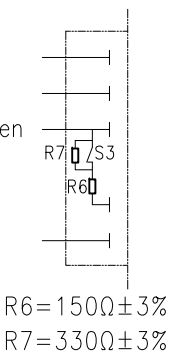

X1

Laser Printing Front Note:

Laser Printing Back Note(Arial):
 MAAC-S-032A-V-03-5.0M-86AH
 32A 240V AC
 SAE J1772:2017
 Type 3R
 20xxxxxx-xxxx

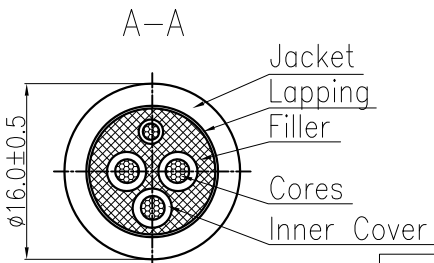

额定电压电流/Rated Voltage/Current	240V AC/32A
绝缘电阻/Insulate Resistance	>100MΩ, 500V DC 1min
耐压/Withstanding Voltage	L, N and PE ,2500V AC 1min L and N ,2500V AC 1min
防护等级/Ingress Protection	Type 3R
插拔寿命/Insertion/Pullout Times	10,000 Times
插拔力/Insertion/Pullout Force	<75N
使用温度范围/Operating temperature(°C)	-30~+50
线材规格/Cable specification	3*10AWG+1*18AWG Black
标准/Reference standard	SAE J1772:2017
符合RoHS环保要求/Conform to RoHS	Yes

		MATERIAL:	SURFACE/COLOR:
MAT NO/REV: DO-1		MAT STATUS:	
NAME MAAC-S-032A-V-03-5.0M-86A(H)			
APPD: Ye DB 2024.09.29	CHKD: Dong RT 2024.09.29	DRAWING NO.	TYPE
DRFT: Hu MY 2024.09.29		CUSTOMER DRAWING	DRAWING STATUS
SCALE 1:3		SHEET 1/1	

REV	ECN	DESCRIPTION	DRFT	DATE

Transfer or duplication of this document as well as the utilization or commercialization of its contents are prohibited unless authorized in writing by DEQSON. All rights reserved for patent, copyright, trademark, or other intellectual property rights. 复制或翻印本文件内容、未经许可擅自使用其内容、或进行商业应用等行为，均属于侵权行为，本公司保留追究法律责任的所有权利。