

未注公差/General tolerances (mm)												0.1/10 ±2'		
0 ~ 3	>3 ~ 6	>6 ~ 10	>10 ~ 18	>18 ~ 30	>30 ~ 50	>50 ~ 80	>80 ~ 120	>120 ~ 180	>180 ~ 250	>250 ~ 315	>315 ~ 400		>400 ~ 500	>500
±0.12	±0.18	±0.22	±0.26	±0.31	±0.37	±0.57	±0.80	±0.93	±1.05	±1.15	±1.60	±2.20	±2.50	

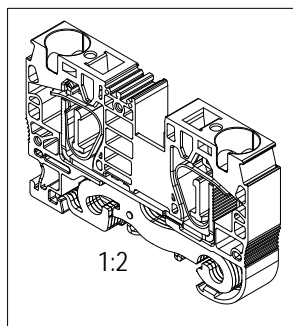

详图 D

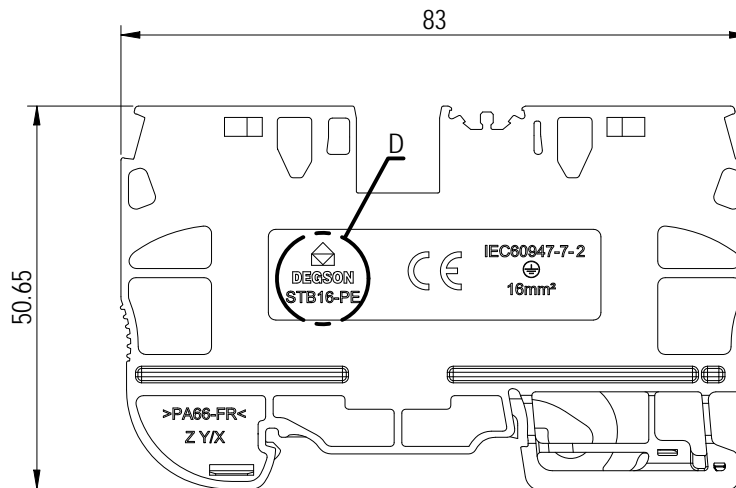
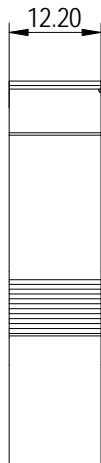
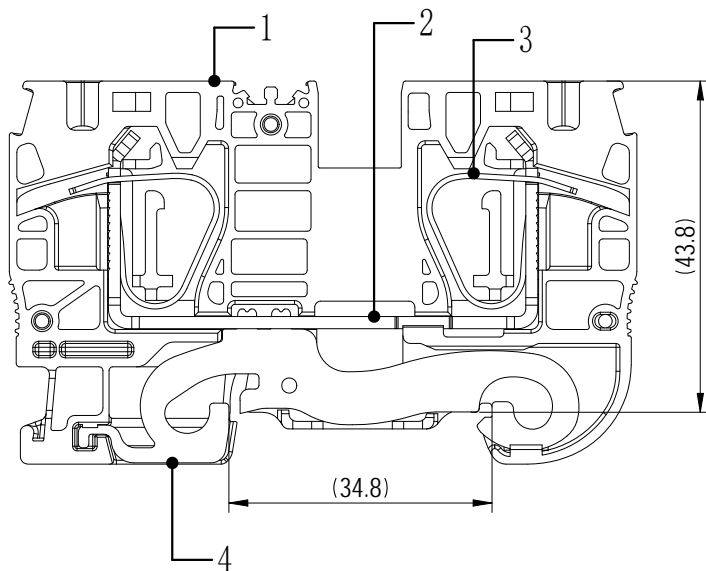
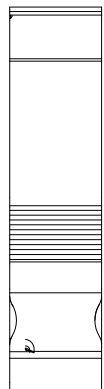
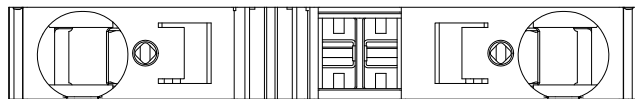

ITEM	NAME OF PART	MATERIAL	NOTES
4	PE	Copper Alloy	Sn Plated
3	Spring	Stainless	/
2	Current Carrier	Copper Alloy	Sn Plated
1	Housing	PA66	UL94 V-0

UL 标准/UL Standard:	B	C	D
额定电压/电流/Rated Voltage(V)/Current(A)	/	/	/
IEC 标准/IEC Standard:			
过压类别/Ovenvoltage Category/污染等级/Pollution Degree	III/3	III/2	II/2
额定电压/电流/Rated Voltage(V)/Current(A)	/	/	/
额定脉冲电压(KV)/Rate Impulse Voltage(KV)	8	8	8
螺丝扭矩/Torque Tightening(N·m/Lb.in)	/		
线径范围(硬线和软线)/Wire Range(rigid and flexible)(AWG/mm²)	24~4 / 0.2~25		
间距/Pitch(mm)/线数范围/Poles	12.20/N=01P		
剥线长度/Stripping length(mm)	17~18		
使用温度范围/Operating temperature(°C)	-60~+105		
符合RoHS环保要求/Conform to RoHS	Yes		

		MATERIAL:	SURFACE/COLOR:	
APPD: PENG M 2024.06.04		MAT NO./REV: 1110000045-1 / 00		MAT STATUS: 设计放行
CHKD: GAO WG 2024.06.04		NAME		
DRFT: GAO WG 2024.06.04		STB16-PE-01P-1C-00Z (H)		
DRAWING NO.	TYPE	DRAWING STATUS	SCALE	SHEET
200283445	CUSTOMER DRAWING	已发布	2:1	1/1

REV	ECN	DESCRIPTION	DRFT	DATE
01		Update 2D according to the latest design	GAO WG	2024.06.04

Transfer or duplication of this document as well as the utilization or communication of its content are prohibited unless authorized in writing. All rights reserved for patent. Utility model or design registrations. 除专利权明确标注外，其他内容均受专利、实用新型及外观设计保护。未经许可，不得复制或传播。 本公司保留对涉及发明、实用新型和外观设计的所有权利。