

Screwdriver hole: 0.6x3.6 elbow screwdriver is recommended

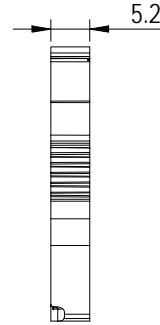

未注公差/General tolerances (mm)											0.1/10 ±2'			
0 ~ 3	>3 ~ 6	>6 ~ 10	>10 ~ 18	>18 ~ 30	>30 ~ 50	>50 ~ 80	>80 ~ 120	>120 ~ 180	>180 ~ 250	>250 ~ 315		>315 ~ 400	>400 ~ 500	>500
±0.12	±0.18	±0.22	±0.26	±0.31	±0.37	±0.57	±0.80	±0.93	±1.05	±1.15	±1.60	±2.20	±2.50	

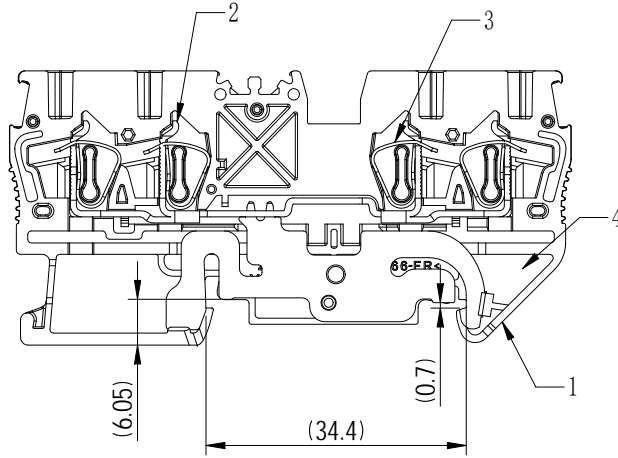
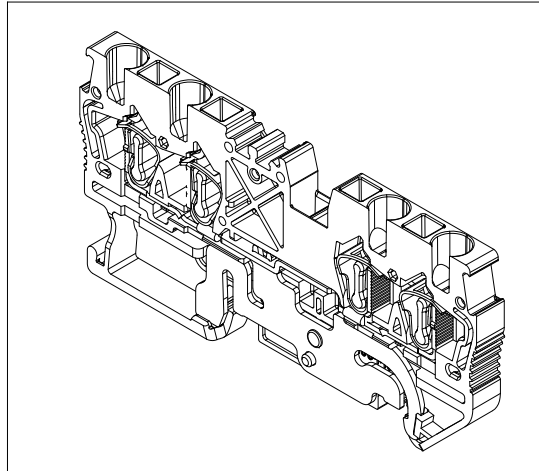
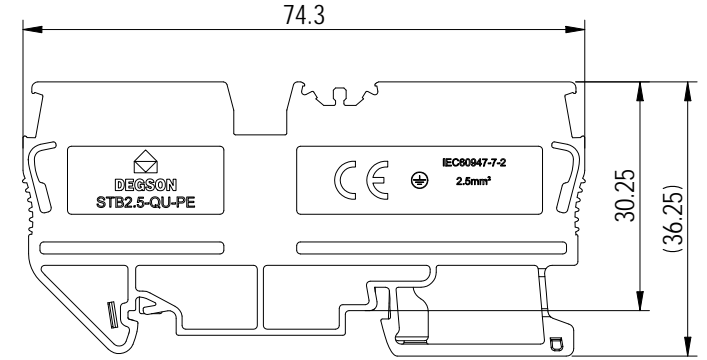

ITEM	NAME OF PART	MATERIAL	NOTES
4	PE	Copper Alloy	Sn Plated
3	Spring	Stainless	/
2	Current Carrier	Copper Alloy	Sn Plated
1	Housing	PA66	UL94 V-0

UL 标准/UL Standard:		B	C	D
额定电压/电流/Rated Voltage(V)/Current(A)		/	/	/
IEC 标准/IEC Standard:				
过压类别/Overvoltage Category/污染等级/Pollution Degree		III/3	III/2	II/2
额定电压/电流/Rated Voltage(V)/Current(A)		/	/	/
额定脉冲电压(KV)/Rate Impulse Voltage(KV)		8	/	/
线径范围(硬线和软线)/Wire Range(rigid and flexible)(AWG/mm²)		28~12 / 0.08~4.0		
间距/Pitch(mm)/线数范围/Poles		5.2/N=01P		
剥线长度/Stripping length(mm)		8~10		
使用温度范围/Operating temperature(°C)		-40~+105		
符合RoHS环保要求/Conform to RoHS		Yes		

APPD: PENG M	2024.09.24
CHKD: GAO WG	2024.09.23
DRFT: GAO WG	2024.09.23

MATERIAL:	SURFACE/COLOR:		
MAT NO./REV: 11030000817-1 / 01.03	MAT STATUS: 批量		
NAME			
STB2.5-QU-PE-01P-1C-00A&Z(H)			

OS	ECN	DESCRIPTION	DRFT	DATE	比例尺
08		Release mass production version:	GAO WG	2024.09.23	A4
REV	ECN	DESCRIPTION	DRFT	DATE	(inch)

DRAWING NO.	TYPE	DRAWING STATUS	SCALE	SHEET
200134336	CUSTOMER DRAWING	已发布	1:1	1/1

Transfer or duplication of this document as well as the utilization or communication of its content are prohibited unless authorized in writing by Degson. All rights reserved for patent, utility model or design registrations. 除专利权明确授权外，未经许可不得复制或传播。 未经授权，不得复制或传播。 未经授权，不得复制或传播。 未经授权，不得复制或传播。