

未注公差/General tolerances (mm)													0.1/10 ±2'
0	>3	>6	>10	>18	>30	>50	>80	>120	>180	>250	>315	>400	
~3	~6	~10	~18	~30	~50	~80	~120	~180	~250	~315	~400	~500	>500
±0.12	±0.18	±0.22	±0.26	±0.31	±0.37	±0.57	±0.80	±0.93	±1.05	±1.15	±1.60	±2.20	±2.50

Screwdriver hole: 0.6x3.6 elbow screwdriver is recommended

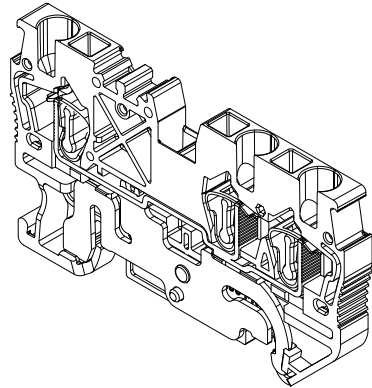
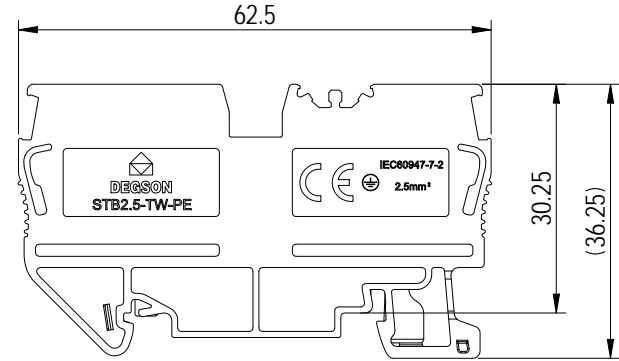
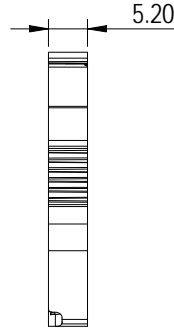
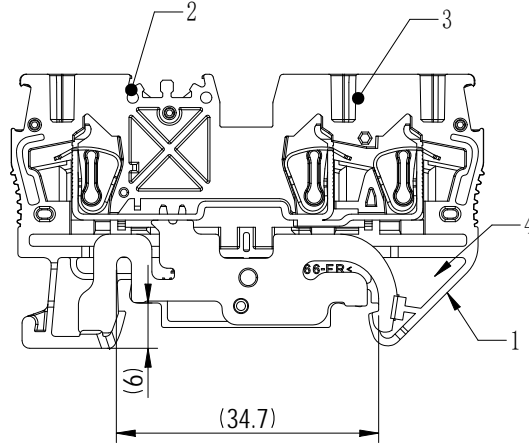

4	PE	Copper Alloy	Sn Plated
3	Spring	Stainless	/
2	Current Carrier	Copper Alloy	Sn Plated
1	Housing	PA66	UL94 V-0
ITEM	NAME OF PART	MATERIAL	NOTES

UL 标准/UL Standard:	B	C	D
额定电压/电流/Rated Voltage(V)/Current(A)	/	/	/
IEC 标准/IEC Standard:			
过压类别/Overvoltage Category/污染等级/Pollution Degree	III/3	III/2	II/2
额定电压/电流/Rated Voltage(V)/Current(A)	/	/	/
额定脉冲电压(KV)/Rate Impulse Voltage(KV)	8	/	/
线径范围(硬线和软线)/Wire Range(rigid and flexible)(AWG/mm²)	硬线: 28~12/0.08~4.0 软线: 28~14/0.08~2.5		
间距/Pitch(mm)/线数范围/Poles	5.2/N=01P		
剥线长度/Stripping length(mm)	8~10		
使用温度范围/Operating temperature(°C)	-40~+105		
符合RoHS环保要求/Conform to RoHS	Yes		

DEGSON		MATERIAL:	SURFACE/COLOR:		
APPD: PENG M 2024.10.23		MAT NO./REV: 1103000830-1 / 00.02		MAT STATUS: 批量	
CHKD: GAO WG 2024.10.23		NAME			
DRFT: GAO WG 2024.10.23		STB2.5-TW-PE-01P-1C-00Z(H)			
DRAWING NO.	TYPE	DRAWING STATUS	SCALE	SHEET	
200171513	CUSTOMER DRAWING	已发布	1:1	1/1	

REV	ECN	DESCRIPTION	DRFT	DATE	④	⑤	A4	(inch)
03		Release mass production version;	GAO WG	2024.10.23				

Transfer or duplication of this document as well as the utilization or communication of its contents are prohibited unless authorized in writing. All rights reserved for patent, utility model or design registrations. 除专利、实用新型、外观设计、发明专利、软件著作权、集成电路布图设计专有权、商业秘密和与著作权有关的财产权外，其他权利均归本公司所有。未经许可，不得复制或传播。