

Transfer or duplication of this document as well as the utilization or communication of its contents are prohibited unless authorized in writing. All rights reserved for patent, utility model or design registrations. 除专利号明确标注外, 否则禁止转让、复制、引用, 尤其禁止文件的再发布。 一经发现侵权必究, 侵权必究。 本公司保留对涉及发明、实用新型和外观设计的所有权利。

未注公差/General tolerances (mm)													0.1/10 ±2'
0	>3	>6	>10	>18	>30	>50	>80	>120	>180	>250	>315	>400	
~3	~6	~10	~18	~30	~50	~80	~120	~180	~250	~315	~400	~500	
±0.12	±0.18	±0.22	±0.26	±0.31	±0.37	±0.57	±0.80	±0.93	±1.05	±1.15	±1.60	±2.20	±2.50

UL 标准/UL Standard:	B	C	D
额定电压/电流/Rated Voltage(V)/Current(A)	300V/20	300V/20	600V/5
IEC 标准/IEC Standard:			
过压类别/Overvoltage Category/污染等级/Pollution Degree	III/3	III/2	II/2
额定电压/电流/Rated Voltage(V)/Current(A)	400V/20	/	/
额定脉冲电压(KV)/Rate Impulse Voltage(KV)	6	/	/
线径范围(硬线和软线)/Wire Range(rigid and flexible)(AWG mm <sup>2</sup> )	26~ 12/ 0.14~ 2.54(sol)		
间距/Pitch(mm)/线数范围/Poles	5.2/N= 01P		
剥线长度/Stripping length(mm)	10~ 12		
使用温度范围/Operating temperature(°C)	-40~ + 105		
符合 RoHS 环保要求/Conform to RoHS	Yes		
标准颜色编号/Standard color number: PANTONE/ RAL	/		

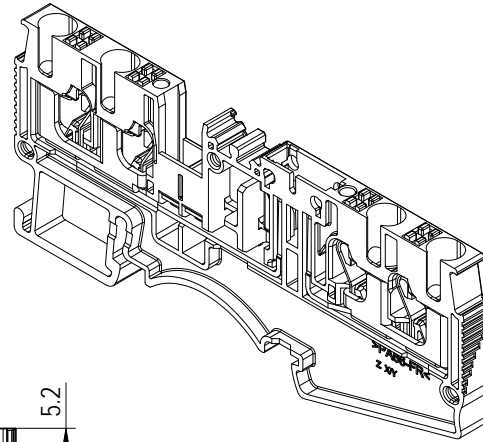
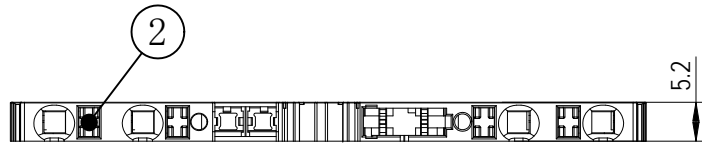

5	Current carrier 2	Copper	Sn Plated
4	Current carrier 1	Copper	Sn Plated
3	Spring	Stainless steel	/
2	Button	PA66+GF%	UL94V-0
1	Housing	PA66	UL94V-0
ITEM	NAME OF PART	MATERIAL	NOTES

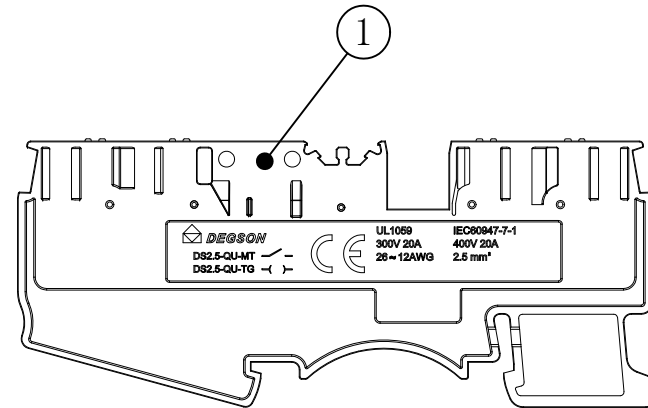
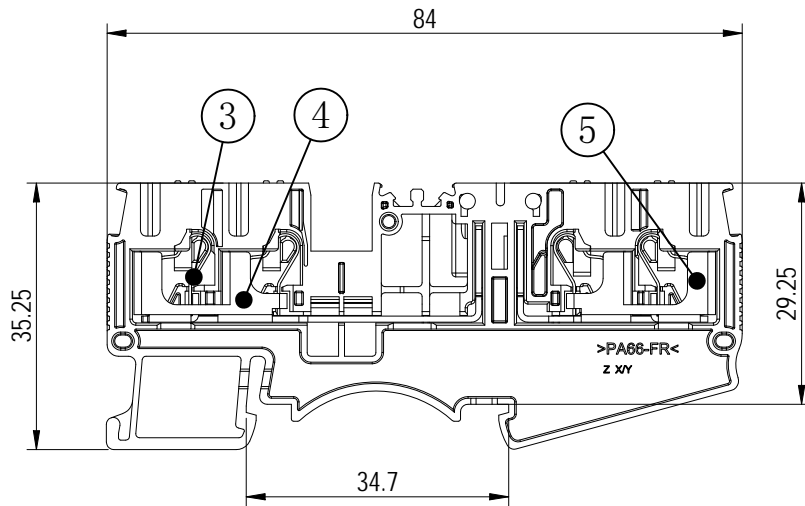

		MATERIAL:	SURFACE/COLOR:		
		MAT NO./REV:	/	MAT STATUS: 批量	
APPD: Li GL	2022.11.03	NAME			
CHKD: Ma EK	2022.11.01	DS2.5-QU-TG-01P-1Y-00Z(H)			
DRFT: Zhao QX	2022.10.27				
DRAWING NO.	TYPE	DRAWING STATUS	SCALE	SHEET	
200068957	CUSTOMER DRAWING	已发布	2:1	1/1	

REV	ECN	DESCRIPTION	DRFT	DATE	比例 (inch)
00		NEW DRAWING	Zhao QX	2022.10.27	A4