

DEMR Series Electricity Meter

Installation and Operation Instructions T1.0



Statement

All rights reserved. Without the written permission of the Company, any paragraph or section of this manual shall not be extracted, copied or reproduced or distributed in any form. Otherwise, all consequences shall be borne by the violator.

The Company reserves all legal rights.

Our Company reserves the right to modify the product specifications described in this manual without further notice. Please consult your local agent for the current specifications of this product before placing an order.

safe Information

This manual does not contain all of the safety measures for operation of the equipment(module, device),because special operating conditions, and local code requirements or regulations may necessitate further measures. However,it does contain information which must be read for your personal safety and to avoid material damages. This information is highlighted by a warning triangle and is represented as follows, depending on the degree of potential danger.



DANGER indicates a hazardous situation which, if not avoided, will result indeath or serious injury.
Failure to follow these instructions will result in death or serious injury.



WARNING indicates a hazardous situation which, if not avoided, could resultin death or serious injury.



CAUTION indicates a hazardous situation which, if not avoided, could result inminor or moderate iniury.

Contents

1. Overview	1
2. Description of Model	1
3 List of Functions	2
4 Technical Parameters	2
5 Overall Dimensions	4
5.1 Instrument Dimensions	4
5.2 Transformer Dimensions	5
6 safety measures	5
7 Connection and Installation	6
7.1 Installation	6
7.2 Schematic Diagram of Voltage and Current Connection	6
7.3 Functional Terminal	8
8 Main Functional Features	9
8.1 Measurement Function	9
8.2 Metering Function	9
9 Operation and Display	9
9.1 Key Function Description	9
9.2 Display Interface	10
10 Communication Instructions	10
10.1 Address Table	11
11 Common Fault Analysis	14
11.1 Display Fault (Abnormal Voltage, Current, and Power Indications)	14
11.2 Communication Fault	14
12 Transportation and Storage	14
13. Warranty and Service	14

1. Overview

DEMР series DIN-rail mounted multifunctional electric energy meter is an intelligent instrument mainly designed for new energy power generation systems such as photovoltaic grid-connected system, micro inverter system, energy storage system, AC coupling system, etc. The product has the advantages of high precision, small volume, high respondent speed and convenient installation. The product has the features of sampling, metering and monitoring power parameters, communicating with an inverter or an energy management system (EMS), realizing the functions of preventing reverse flow, regulating power generation, charging and discharging batteries according to real-time power and accumulated electric energy, and realizing bidirectional metering and household distributed photovoltaic energy management.

2. Description of Model

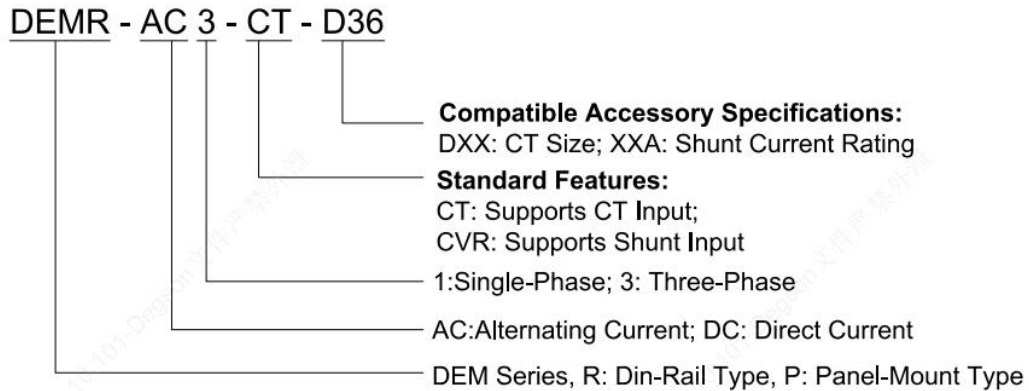

3 List of Functions

Table 1 List of Function Descriptions

Function	Descriptions	DEMR-AC1-CT
Electric energy metering	Active energy metering (forward and reverse)	■
	Reactive energy metering (forward and reverse)	■
Electric quantity measurement	U, I	■
	P, Q, S, PF, F	■
LCD display	Segmented LCD display	■
Pulse output	Active pulse output	■
Communication	RS485: Modbus RTU	■

4 Technical Parameters

Table 2 Description of Technical Parameters

Item		Performance Parameters		
Model Series		DEMR-AC1-CT		
Measurement	Grid		Single-phase	
	Voltage	Rated voltage	AC 230V	
		Input Range	$\pm 20\%$	
		Overload	1.2 times rating (continuous) 2 times the rating for 1 second	
		Power consumption	<2W, <10VA	
		Accuracy class	Error $\pm 0.5\%$	
	Current	Input current	AC 0.5-10(80)A, AC 0.5-10(120)A	
		Overload	1.2 times rating (continuous) 2 times the rating for 1 second	
		Power consumption	<1W, <1VA	
		Accuracy class	Error $\pm 0.5\%$	
	Power		Active, reactive, apparent power, error $\pm 0.5\%$	
	Grid frequency		50/60Hz, error $\pm 0.5\%$	
	Response rate		$\leq 100\text{ms}$ (voltage, current, power) $\leq 1\text{s}$ (electrical energy)	
	Measurement category		CAT III	
	overvoltage level		OVC III	

Metering	Electric energy	Active energy : Class B Reactive energy (Class 2 accuracy)
power consumption	$\leq 2W$	
electromagnetic compatibility	E2	
Security	Power frequency withstand voltage	Between communication and signal input, AC3kV 1min
	Insulation resistance	Input and output terminals to casing $>100M\Omega$
Communication	Interface and communication protocol	RS485 interface and Modbus RTU protocol
	Communication address range	Modbus RTU:1~ 247;
	Baud rate	Support 1200bps-38400bps
Environment	Operating temperature	$-40^{\circ}C \sim +70^{\circ}C$
	Storage temperature	$-40^{\circ}C \sim +80^{\circ}C$
	Relative humidity	$\leq 95\%$ (without condensation) "Not suitable for damp environments"
	Altitude	$\leq 2000m$
reference standard	<p>EN IEC 61010-1:2010 Safety requirements for electrical equipment for measurement, control, and laboratory use - Part 1: General requirements</p> <p>EN IEC 61010-2-030:2010 Safety requirements for electrical equipment for measurement, control, and laboratory use - Part 2-030: Particular requirements for equipment having testing or measuring circuits</p> <p>EN IEC 61326-1:2021 Electrical equipment for measurement, control, and laboratory use - EMC requirements - Part 1: General requirements</p> <p>EN IEC 61326-2-1:2021 Electrical equipment for measurement, control, and laboratory use - EMC requirements - Part 2-1: Particular requirements for electromagnetic compatibility testing for electrical equipment for measurement, control, and laboratory use</p> <p>EN 50470-3 Electricity metering equipment (a.c.) - Part 3: Particular requirements - Static meters for active energy (class indexes A, B and C)</p>	
IP	IP 51 (Must be installed in a suitable IP rated enclosure)	
Pollution Degree	II	

UC Degree	III
Installation environment	Indoor use
Protect Degree	Class II (Double Insulation)
usage environment	Cabinet mounted(The outer shell cannot be touched)
usage environment	M1
Transformer Safety characteristics	<p>Insulation resistance: greater than 1000 MΩ under normal conditions;</p> <p>Electric strength resistance: It can withstand 4000V, 50Hz power frequency for 1 minute;</p> <p>Flame retardancy: Conforms to UL94-V0 level;</p>

5 Overall Dimensions

5.1 Instrument Dimensions

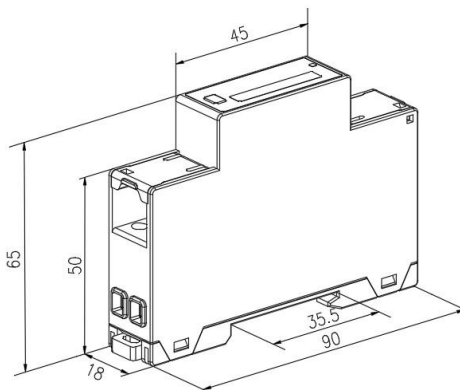

5.2 Transformer Dimensions

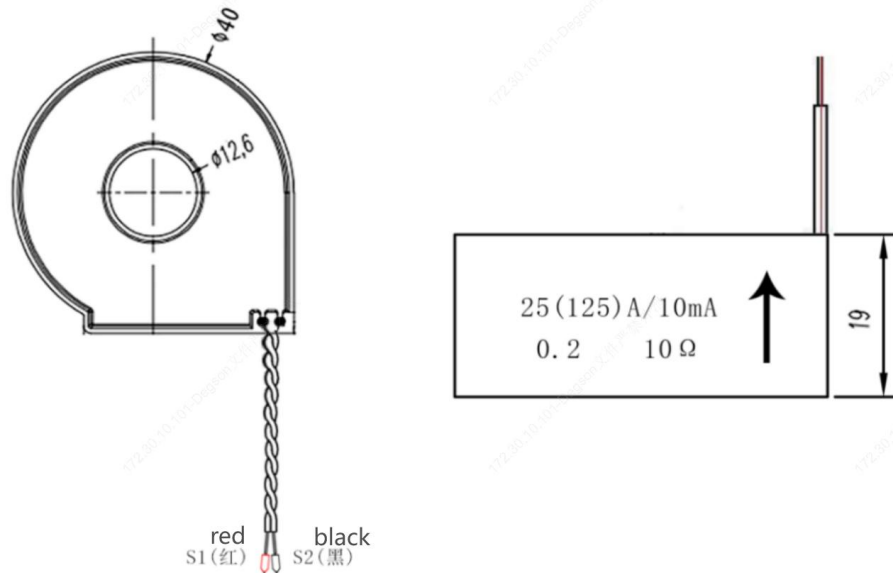

6 safety measures

HAZARD OF ELECTRIC SHOCK, EXPLOSION, OR ARC FLASH

- Apply appropriate personal protective equipment (PPE) and follow safe electrical work practices.
- This equipment does not require commission before use.
- Turn off all power supplying this device and the equipment in which it is installed before working on it.
- Always use a properly rated voltage sensing device to confirm that all power is off.
- Do not exceed the device's ratings for maximum limits.
- Do not use this device for critical control or protection applications where human or equipment safety relies on the operation of the control circuit.
- Do not use water or any liquid material to clean the product. Use a cleaning cloth to remove dirt.
- The installer is responsible for co-ordinating the rating and the characteristics of the supply side overcurrent protection devices with the maximum current rating. Failure to follow these instructions will result in death or serious injury.



•This is the safety alert symbol. It is used to alert you to potential personal injury hazards. When seeing this symbol, it is necessary to consult the manual.

7 Connection and Installation

7.1 Installation

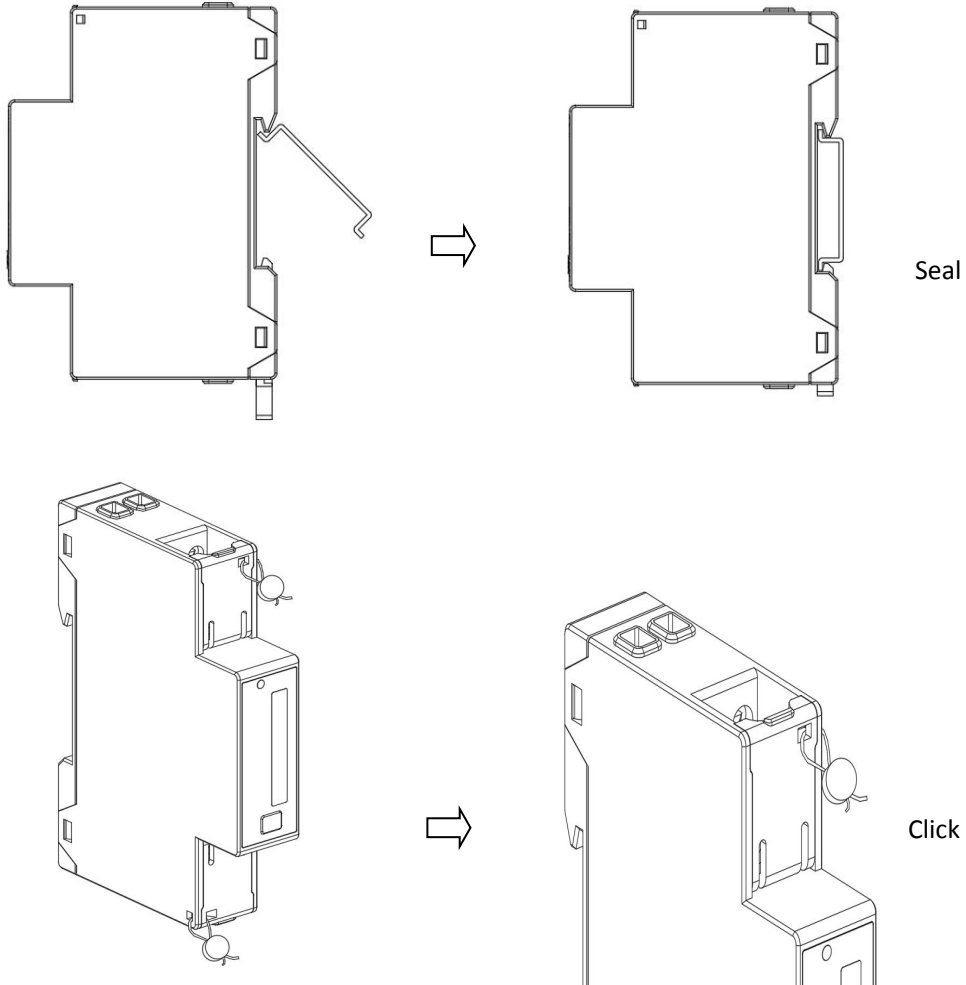

NOTE:

- 1.Once the product is installed,the flip cover needs to be lead-sealed;
- 2.The sealing wires are not provided by DEGSON.;
- 3.Max diameter of the sealing wire $\varnothing \leq 2\text{mm}$;

7.2 Schematic Diagram of Voltage and Current Connection

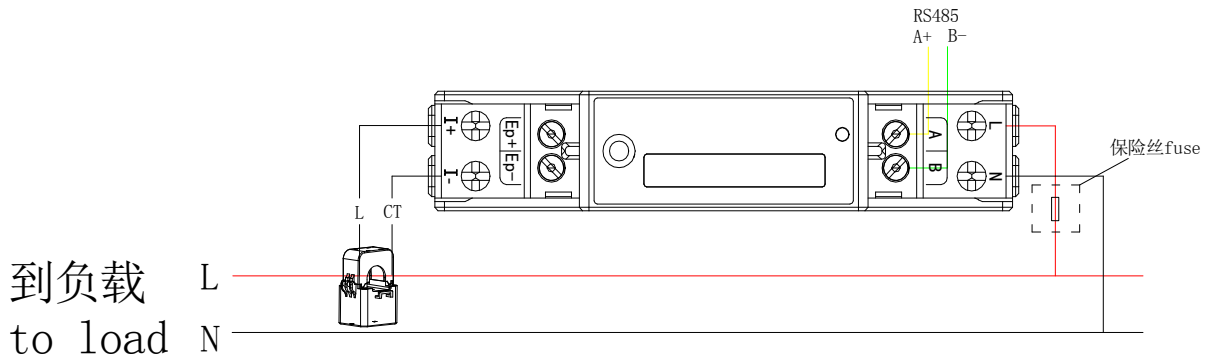

Port	Description	Remark
L	Voltage Line	
N	Neutral Line	
I+	Current Input	
I-	Current output	

- Recommended cross section: 2.5...10mm² (13...7AWG)
- The necessary torque is 2 N•m (17.7 lb-in) .

WARNING

- Use copper wire rated for 500V.
- Minimum temperature rating of the cable to be connected to the field wiring terminals, 80 °C.

Failure to follow these instructions can result in death, serious injury, or equipment damage.

AVERTISSEMENT

- Utilisez un fil de cuivre évalué pour 500V.
- Température nominale minimale du câble à connecter aux bornes de câblage sur le terrain, 80 ° C.

Le non-respect de ces instructions peut entraîner la mort, des blessures graves ou des dommages à l' équipement.

Note:

1. For safety reasons, a fuse with a rated current of 5A needs to be connected to the voltage input terminal;
2. Verify that power is OFF before making connections;

7.3 Functional Terminal

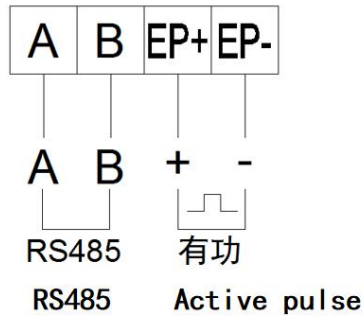

Port	Description	Remark
A	RS485 port A	
B	RS485 port B	
EP+	Active pulse output +	
EP-	Active pulse output -	

- Recommended cross section: 0.25...1.5 mm² (26...16 AWG)
- The necessary torque is 0.5 N•m (4.4 lb-in) .



- means unidirectional RS485 Galvanical port



WARNING

- Use copper wire rated for 500V.
- Minimum temperature rating of the cable to be connected to the field wiring terminals, 80 °C.

Failure to follow these instructions can result in death, serious injury, or equipment damage.



AVERTISSEMENT

- Utilisez un fil de cuivre évalué pour 500V.
- Température nominale minimale du câble à connecter aux bornes de câblage sur le terrain, 80 ° C.

Le non-respect de ces instructions peut entraîner la mort, des blessures graves ou des dommages à l' équipement.

8 Main Functional Features

8.1 Measurement Function

It can measure total power parameters including voltage U, current I, active power P, reactive power Q, apparent power S, power factor PF and frequency. Wherein, the voltage U is reserved with 1 decimal place, the frequency F is reserved with 2 decimal places, the current I is reserved with 2 decimal places, and the power P is reserved with 3 decimal places.

For example, $U = 220.1V$, $f = 49.98Hz$, $I = 1.99A$, $P = 0.439kW$

The above electrical parameter high-speed response registers are also provided with the instrument, see Chapter 9 “Communication Instructions”.

8.2 Metering Function

It can measure the current combined active electric energy, forward active electric energy, reverse active electric energy, forward reactive electric energy and reverse reactive electric energy.

9 Operation and Display

9.1 Key Function Description

Table 2 Explanation of Indicator Lights

Indicator name	illustrate
E	1/600kwh Pulse indicator light, if the pulse constant is 600, each pulse represents 1/600kwh of electricity

9.2 Display Interface

DEMР-AC1:

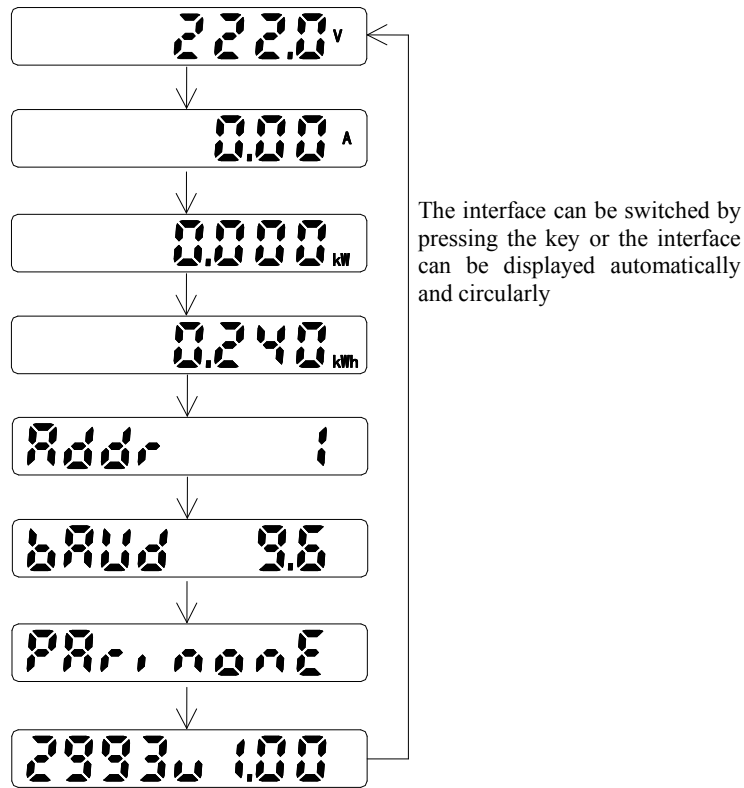

10 Communication Instructions

The instrument RS485 communication interface supports MODBUS-RTU communication protocol. The baud rate of communication interface can be set between 1,200bps, 2,400 bps, 4,800 bps, 9,600bps, 19,200 bps and 38,400 bps, and the check bit is no check.

The RS485 communication interface of the instrument requires shielded twisted pair connection, and the layout of the whole grid should be considered when wiring: For example, the length and direction of communication cable, the position of upper computer, the matching resistance at the end of the grid, the communication converter, the scalability of the grid, the coverage of the grid, the electromagnetic interference of the environment and other factors should be considered comprehensively.

Note:

1. It shall strictly construct according to the requirements in the wiring project;
2. For instruments that do not need communication temporarily, they should be connected to RS-485 grid for diagnosis and test;
3. When connecting RS-485 cable, try to use two-color twisted pair. All 485 communication ports "A" are terminated in the same color, and "B" is terminated in another color.
4. The length of RS-485 bus (from the communication interface of the upper computer to any connected instrument terminal communication interface) shall not exceed 1,000 meters.

10.1 Address Table

Meter supports 03H command and 10H command in MODBUS-RTU protocol, in which 03H for reading multiple registers and 10H for writing multiple registers. Please check the protocol data format by yourself. The following table is the register address table of the meter:

Table 5 Communication Address Table

Address	Name	R/W	Length (Bytes)	Type	Unit	Note
1000H	slave address	R/W	1	uint16		1-247
1001H	baud rate	R/W	1	uint16		1200, 2400, 4800, 9600, 19200, 38400,
1002H	parity	R/W	1	uint16		低字节 Low Byte 0: 无校验 None 1: 奇校验 Odd 2: 偶校验 Even 高字节 High Byte 0: 1stop 1: 1.5stop 2: 2stop
1010H	Grid	R/W	1	uint16		0:3P4L 1:3P3L
1011H	rated second voltage	R/W	1	uint16	0.1V	0.1-999. 9V
1012H	rated second current	R/W	1	uint16	0.01A	0.01-999. 99A
1015H	rated primary voltage	R/W	1	uint32	0.1V	0.1-99999.9V
1017H	rated primary current	R/W	1	uint32	0.01A	0.01-9999. 99A
101DH	Password	R/W	1	uint16		1-9999
101EH	Pulse constant	R/W	1	uint16		1-99999
101FH	Voltage shielding value	R/W	1	uint16	0.01%	
1020H	Current shielding value	R/W	1	uint16	0.01%	
1023H	Power-on default interface	R/W	1	uint16		0: Automatic wheel display Others: Other interfaces
1035H	Apparent power calculation mode	R/W	1	uint16		0: RMS 1: PQS
2000H	A-phase voltage	R	2	float	V	1.Slow register 2.DEMR-AC1 only has A-phase data
2002H	B-phase voltage	R	2	float	V	
2004H	C-phase voltage	R	2	float	V	
2006H	AB-line voltage	R	2	float	V	
2008H	BC-line voltage	R	2	float	V	
200AH	CA-line voltage	R	2	float	V	
200CH	A-phase current	R	2	float	A	
200EH	B-phase current	R	2	float	A	
2010H	C-phase current	R	2	float	A	

2012H	N-phase current	R	2	float	A	
2014H	A-phase active power	R	2	float	kW	
2016H	B-phase active power	R	2	float	kW	
2018H	C-phase active power	R	2	float	kW	
201AH	Total active power	R	2	float	kW	
201CH	A-phase reactive power	R	2	float	Kvar	
201EH	B-phase reactive power	R	2	float	Kvar	
2020H	C-phase reactive power	R	2	float	Kvar	
2022H	total reactive power	R	2	float	Kvar	
2024H	A-phase apparent power	R	2	float	KVA	
2026H	B-phase apparent power	R	2	float	KVA	
2028H	C-phase apparent power	R	2	float	KVA	
202AH	Total apparent power	R	2	float	KVA	
202CH	A-phase power factor	R	2	float		
202EH	B-phase power factor	R	2	float		
2030H	C-phase power factor	R	2	float		
2032H	Total power factor	R	2	float		
2034H	Frequency	R	2	float	Hz	
2100H	A-phase voltage	R	2	float	V	
2102H	B-phase voltage	R	2	float	V	
2104H	C-phase voltage	R	2	float	V	
2106H	AB-line voltage	R	2	float	V	
2108H	BC-line voltage	R	2	float	V	
210AH	CA-line voltage	R	2	float	V	
210CH	A-phase current	R	2	float	A	
210EH	B-phase current	R	2	float	A	
2110H	C-phase current	R	2	float	A	
2112H	N-phase current	R	2	float	A	1.Slow register (response rate <=100ms)
2114H	A-phase active power	R	2	float	kW	2.DEMR-AC1 only has A-phase data
2116H	B-phase active power	R	2	float	kW	
2118H	C-phase active power	R	2	float	kW	
211AH	Total active power	R	2	float	kW	
211CH	A-phase reactive power	R	2	float	Kvar	
211EH	B-phase reactive power	R	2	float	Kvar	
2120H	C-phase reactive power	R	2	float	Kvar	
2122H	total reactive power	R	2	float	Kvar	
2124H	A-phase apparent power	R	2	float	KVA	
2126H	B-phase apparent power	R	2	float	KVA	

2128H	C-phase apparent power	R	2	float	KVA	
212AH	Total apparent power	R	2	float	KVA	
212CH	A-phase power factor	R	2	float		
212EH	B-phase power factor	R	2	float		
2130H	C-phase power factor	R	2	float		
2132H	Total power factor	R	2	float		
2134H	Frequency	R	2	float	Hz	
3000H	active electric energy	R	4	double	kWh	
3004H	forward active electric energy	R	4	double	kWh	
3008H	reverse active electric energy	R	4	double	kWh	
300CH	reactive electric energy	R	4	double	kVarh	
3010H	forward reactive electric energy	R	4	double	kVarh	
3014H	reverse reactive electric energy	R	4	double	kVarh	
3018H	apparent electric energy	R	4	double	kVAh	

11 Common Fault Analysis

11.1 Display Fault (Abnormal Voltage, Current, and Power Indications)

(1) Inspection: Check whether the actual wiring is the same as the requirements of the wiring diagram, pay attention to whether the voltage wiring order is correct, and whether the direction of the current transformer's secondary winding and phase sequence are correct.

(2) Measurement: If the wiring is correct, use a multimeter in continuity test mode to measure the external circuit connections related to the problem. Check for continuity between the terminals of the external circuit and the instrument terminals.

Note: When inspecting current and voltage circuits, ensure that the signal current and voltage are disconnected to ensure personal safety.

11.2 Communication Fault

(1) Inspection: Verify that the communication settings of the instrument, such as the communication address, baud rate, and parity check, match the settings of the master device.

(2) Check if the communication wiring is correct and if A and B are connected incorrectly.

12 Transportation and Storage

The packaging of the instrument should use environmentally friendly materials. The instrument and its accessories, when packaged, should be stored in a ventilated and dry place to avoid moisture and corrosion by gases. The storage temperature should be between -40°C and $+80^{\circ}\text{C}$, with a relative humidity not exceeding 75%.

13.Warranty and Service

The manufacturer offers a triple guarantee on product quality. Within 24 months from the date of manufacture, if the user fully complies with the usage conditions specified in this manual and finds the instrument damaged during use, our company will be responsible for repairing or replacing it free of charge