

DEMР-AC3

Installation and operation instruction T1.6



Declaration

The copyright is the property of DEGSON. Any information in any paragraph or section cannot be extracted, copied or otherwise reproduced or propagated. Otherwise offenders shall take all consequences.

All rights are reserved.

DEGSON reserves the right to modify the product specifications herein without notification. Please consult the local agent about the latest specifications before placing a purchase order.

Date	Old	New	Change
2022.05.17		T1.0	1.First version
2022.08.19	T1.0	T1.1	2.Add direct access model
2023.02.08	T1.1	T1.2	3.Add Device model register
2023.12.21	T1.2	T1.3	4.Added some detailed descriptions
2024.03.21	T1.3	T1.4	5. Add a current specification 6. Add some descriptions of data units 7. Edit the size description image
2024.09.24	T1.4	T1.5	8.Modify the description of the energy accuracy class 9.Amend the torque of connect via CT
2025.04.15	T1.5	T1.6	10.Modify wiring diagram terminal identification 11.Modify address table section description error

Catalog

1 General	- 1 -
2 Type description	- 1 -
3 Function description	- 1 -
4 Technical parameter	- 2 -
5 Outline	- 2 -
6 Wiring and installing	- 3 -
7 Function description	- 5 -
8 Operation and display	- 6 -
9 Communication description	- 12 -

1 General

DEMР-AC3 is a smart meter designed for power supply system, industrial and mining enterprises and utilities to calculate the electricity consumption and manage the electric demand. It features the high precision, small size and simple installation. It integrates the measurement of all electrical parameters with the comprehensive electricity metering and management provides various data on previous 48 months, checks the 2nd-32st subharmonics and the total harmonic content, realizes the remote communication and the remote control with switching input and relay output and boasts the alarm output. It is fitted with RS485 communication port and adapted to MODBUS-RTU. DEMР-AC3 can be used in all kinds of control systems, SCADA systems and energy management systems. The meter meet the related technical requirements of electronic meter in the IEC62053-21standards.

2 Type description

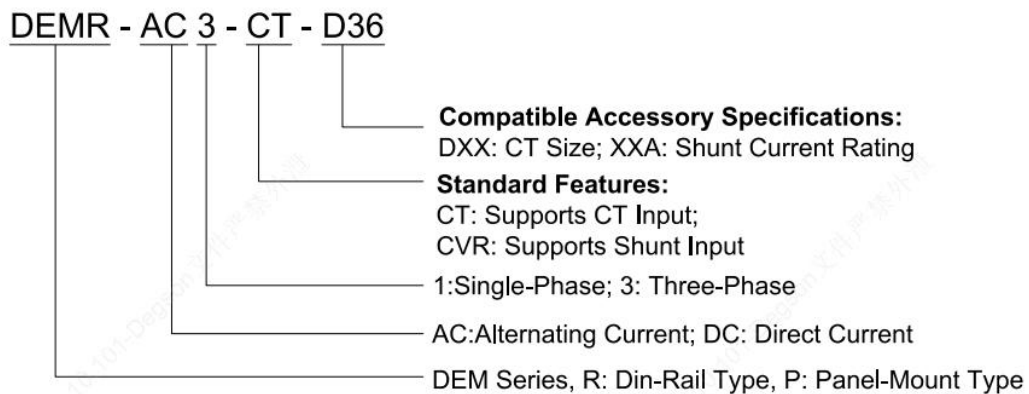

3 Function description

Table 1 Function description list

Function	Function description	Function provide
Measurement of energy	Active kWh (positive and negative)	■
	Reactive kvarh (positive and negative)	■
	A, B, C split phase positive active energy	■
Measurement of electrical parameters	U、 I	■
	P、 Q、 S、 PF、 F	■
Measurement of harmonics	2~31 ST Voltage and current harmonic	■
LCD Display	12 bits section LCD display, background light	■
Key programming	3 keys to communication and set parameters	■
Pulse output	Active pulse output	■

Multi-tariff and functions	Date, time	<input type="checkbox"/>
	Max demanded kWh and time happened	<input type="checkbox"/>
	Frozen data on last 48 months, last 90days	<input type="checkbox"/>
	Adapt 4 time zones, 4 time interval lists, 14 time interval by day and 4 tariff rates	<input type="checkbox"/>
Communication	Communication interface: RS485, Communication protocol: MODBUS-RTU	<input checked="" type="checkbox"/>

4 Technical parameter

Table 2 technical parameter descriptions

project		performance parameter	
Specification		3 phase 4 wires	
Measurement	Voltage	Reference voltage	3×230/400V
		Voltage range	3×57.7/100V~3×276/478V
		Consumption	<10VA(Single phase)
		Impedance	>2MΩ
		Accuracy class	(Error±0.2%)
	Current	Input current	0.01-1(6)A (Secondary access model) 0.1-10(80)A(Direct access model) 0.1-10(100)A(Direct access model)
		Consumption	(Single phase rated current)
		Accuracy class	(Error±0.2%)
Power	Active, reactive, apparent power, error±0.5%		
Frequency	45~65Hz, (Error±0.2%)		
Measurement	Energy	Accuracy class 0.01-1(6)A, 0.1-10(80)A: ClassC 0.1-10(100)A: ClassB	
	Clock	≤0.5s/d	
Digit-signal	Energy pulse output	One active photocoupler output	
pulse	Width of pulse	80±20ms	
	Pulse constant	Direct access model, 400imp/kWh Secondary access model, 10000imp/kWh	
Communication	Interface and communication	RS485: Modbus RTU	
	Range of communication address	Modbus RTU:1~ 247;	
	Baud rate	1200bps~38400bps	
Environment	work environment	Indoor (If it needs to be installed outdoors, please add a dustproof and waterproof shell)	
	Relative temperature	-25℃ to +55℃ (Secondary access model) -40℃ to +70℃(Direct access model)	
	Relative humidity	≤95%(No condensation)	
	IP Rating	IP51 Must be installed in a suitable IP rated enclosure	

5 Dimension drawings

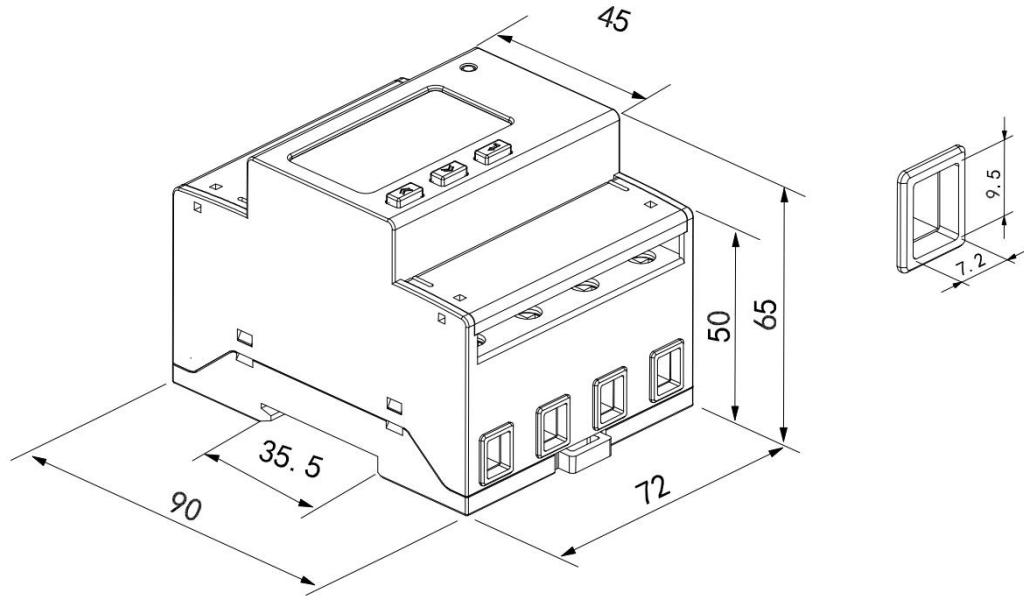

Fig1 DEMR-AC3-CT connect via CT

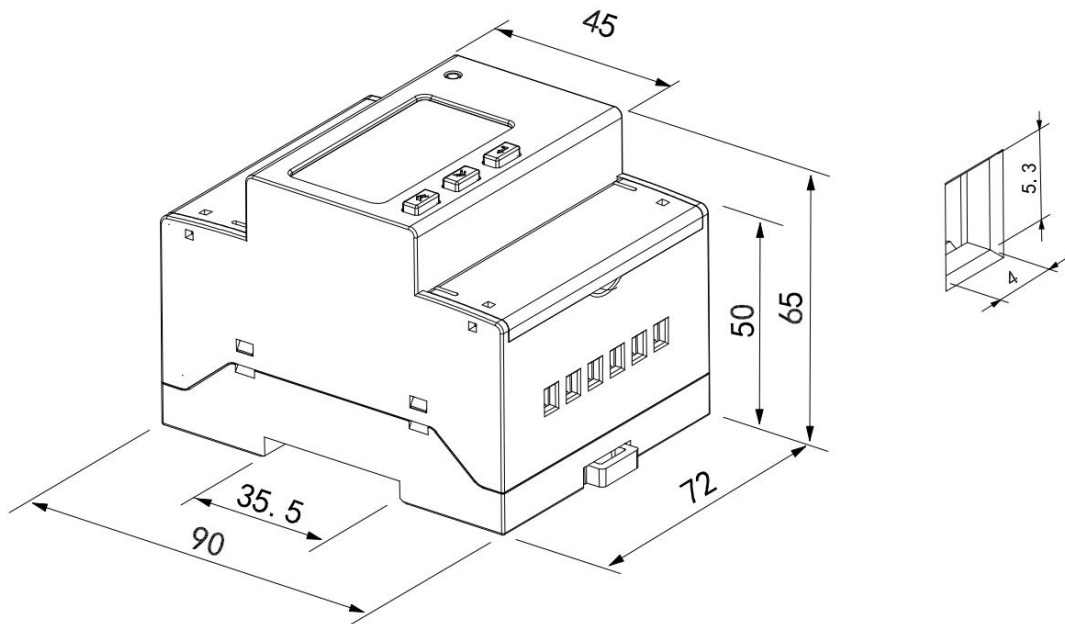

Fig 2 DEMR-AC3 direct connect

Note: The torque of direct connect should be 3-4N·m, and the torque of connect via CT should be 0.5N·m.

6 Wiring and installing

6.1 Wiring sample of voltage and current

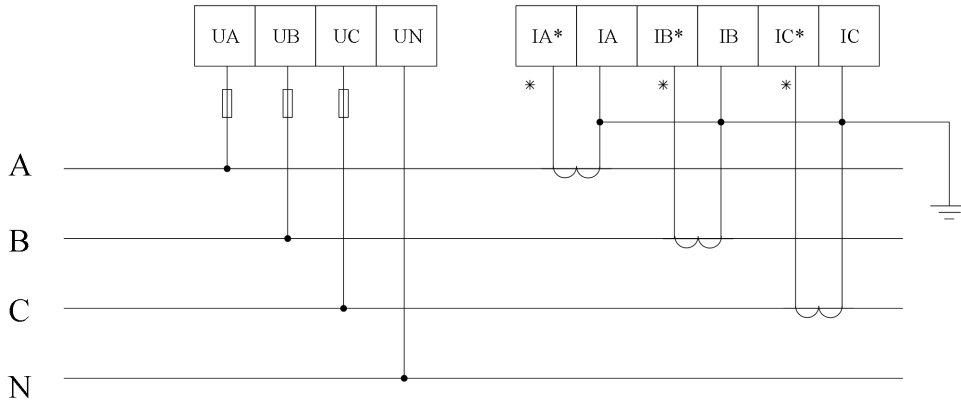

Fig2 Three phase four lines connect via CT

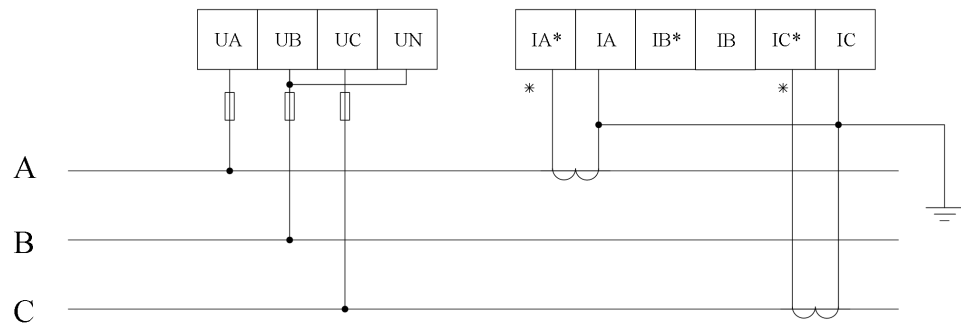

Fig 4 Three phase three lines connect via CT

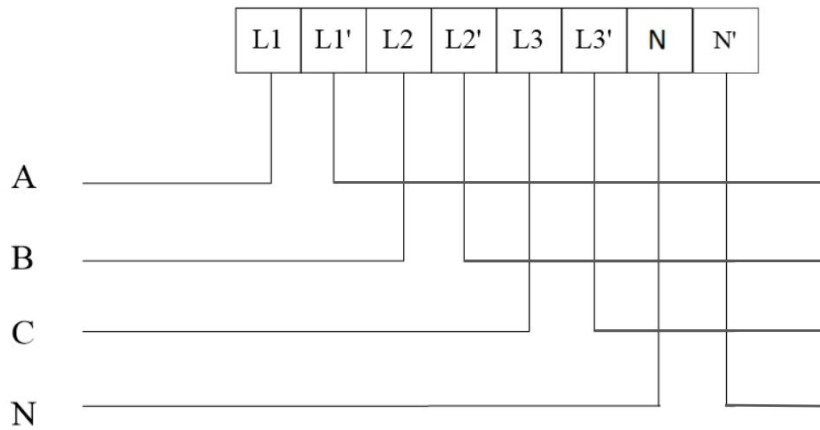

Fig 5 Three phase four lines direct connect

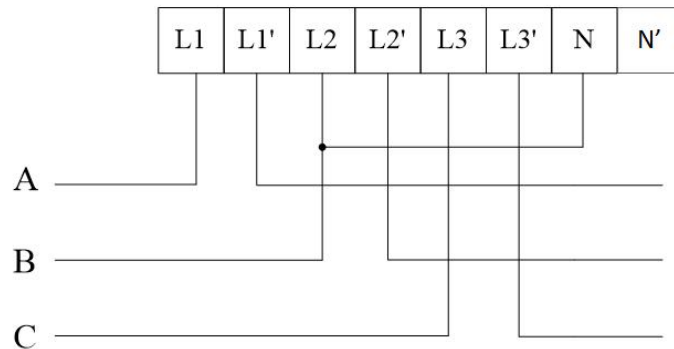

Fig 6 Three phase three lines direct connect

Note:

1. Installation of standard 35mm guide rail (No maintenance, repair or adjustment intended)
2. The meter is intended to be installed in a Mechanical Environment ‘M1’ , with Shock and Vibrations of low significance, as per 2014/32/EU Directive.
3. The meter is intended to be installed in Electromagnetic Environment ‘E2’ , as per 2014/32/EU Directive.

6.2 Wiring diagram of communication and pulse terminals

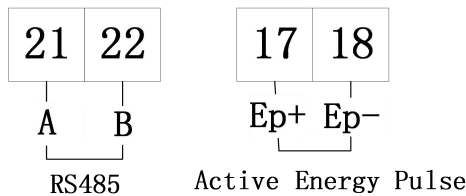

Fig 7 Communication, pulse connection

7 Function description

7.1 Measurement

It can measure the electrical parameter, include U, I, P, Q, S, PF, F, 2nd-31st harmonics and total harmonic content. Such as, U = 220.1V, f = 49.98Hz, I = 1.99A, P = 0.439kW.

7.2 Calculating

Can measure the total active energy, forward active energy, reversing active energy, forward reactive energy, reversing reactive energy.

7.3 Timing

There are four time tables, the year can be divided into four time zones, and every table have fourteen daily time periods and four rates can be set.

7.4 Demand

The description about demand:

Table 3 Demand description list

Demand	The average power in the demand cycle.
Maximum demand	The maximum value of demand in a period of time.
Slip time	The method of measuring the demand from any point in time by a recurrence of time less than the period of the demand is called sliding demand. The recurrence time is called the slip time.
Demand cycle	An equal interval of time between successive measurements of average power, also called window time.

The default demand cycle is 15 minutes, slip time is 1 minute.

The meter can measure 4 kinds of maximum demand, forward active, reversing active, inductance reactive, capacitance reactive maximum demand and the time of occurrence.



7.5 History data statistics

The meter can record last 48 months and last 90 days history energy in each tariff.

8 Operation and display

8.1 Key function description



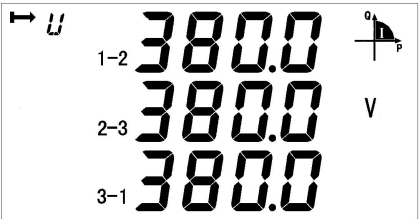
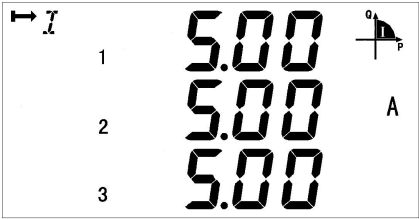

Table 4 Key's function description







icon	Name	Function
	Voltage and current, up	Check the voltage and current Leftward and change flash in programming menu
	Power, down	Check the power Rightward and change the value on flash
	Energy, enter	Check the energy In/out programming menu Save changes

8.2 Display menu

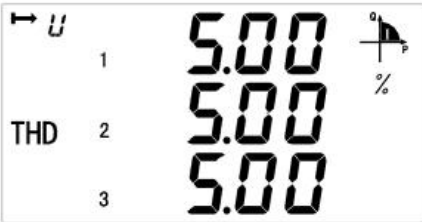
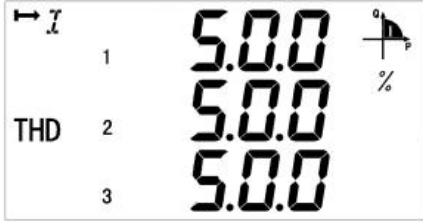
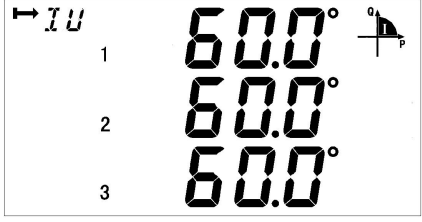

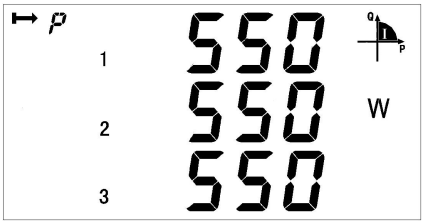

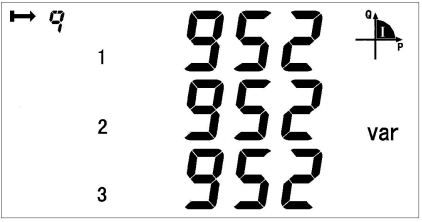



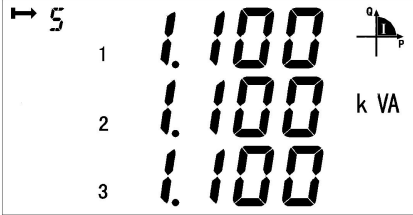
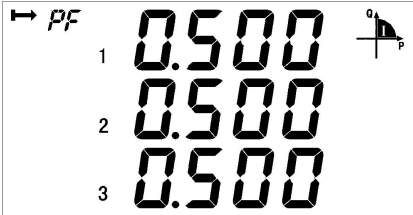

The meter will show the forward active energy after powering. The customers can change the information showing by pressing the keys. The menu description is listed as below.

Table 5 display descriptions

		
	<p>Three-phase voltage</p> 	<p>Three phase line voltage</p> 
	<p>Three-phase Current</p>	<p>Frequency</p>

	 <p>Harmonic content of three phase Voltage</p>	 <p>Harmonic content of three phase Current</p>
	 <p>Phase angle</p>	 <p>Time</p>
	 <p>Three phase active power</p>	 <p>Total active power</p>
	 <p>Three phase reactive power</p>	 <p>Total reactive power</p>

Check bit, baud rate, meter address, And software version number, Software unique identifier, full display detection.

	 <p>Three phase apparent power</p>  <p>Three phase power factor</p>	 <p>Total apparent power</p>  <p>Total power factor</p>
	<p>T3 represents the normal period, ① represents the first time table</p>  <p>Current total active energy</p>  <p>Current spike active energy</p>  <p>Current peak active energy</p>  <p>Current flat active energy</p>  <p>Current valley active energy</p>  <p>Current forward active total energy</p>	

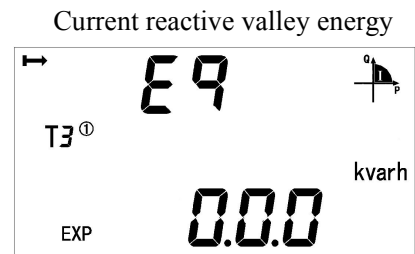
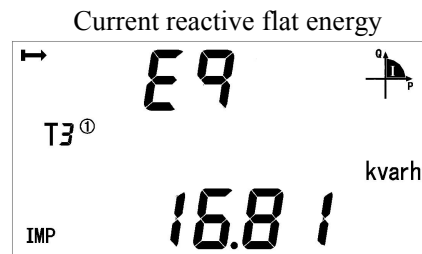
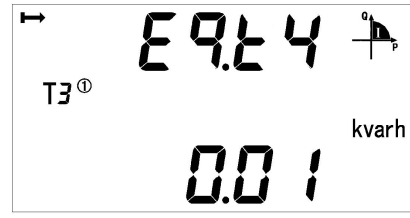

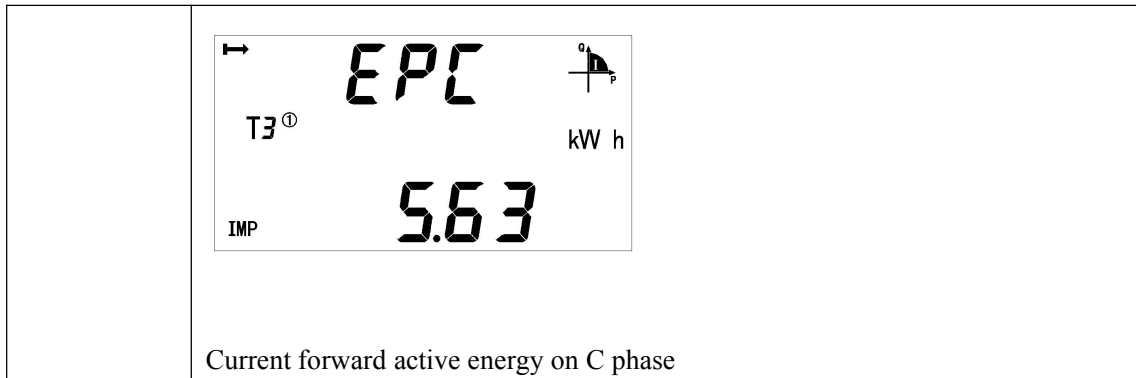





Note,

1. All the display menus above are in the model of DEMR-AC3 three phases four lines with multi-tariff rate function and can be changed by the keys.
2. There will not be power or power factor on each phase and will only show total power and power factor (active, reactive, apparent) under the three phase three lines.
3. There will not be date, time, maximum demand and energy by time without the function of multi-tariff rate.
4. The arrow in the upper left corner of the screen represent the DIR settings, from left to right means that DIR is set to 0; if the arrow is from right to left, it indicates that DIR is set to 1.
5. 'IMP' in the lower left corner of the screen means forward, and 'EXP' means reverse.

8.3Key Menu

Keep press  at any main menu and get in "PASS" interface, and then press  show "0000", and enter the code. If you enter a wrong code, it will show "fail" and back to main menu; and if you enter a right code, you can set the parameter. After setting the parameter and keep press , it will show "save" and save the change by pressing  in "yes" interface and quit without save by pressing  in "no" interface.

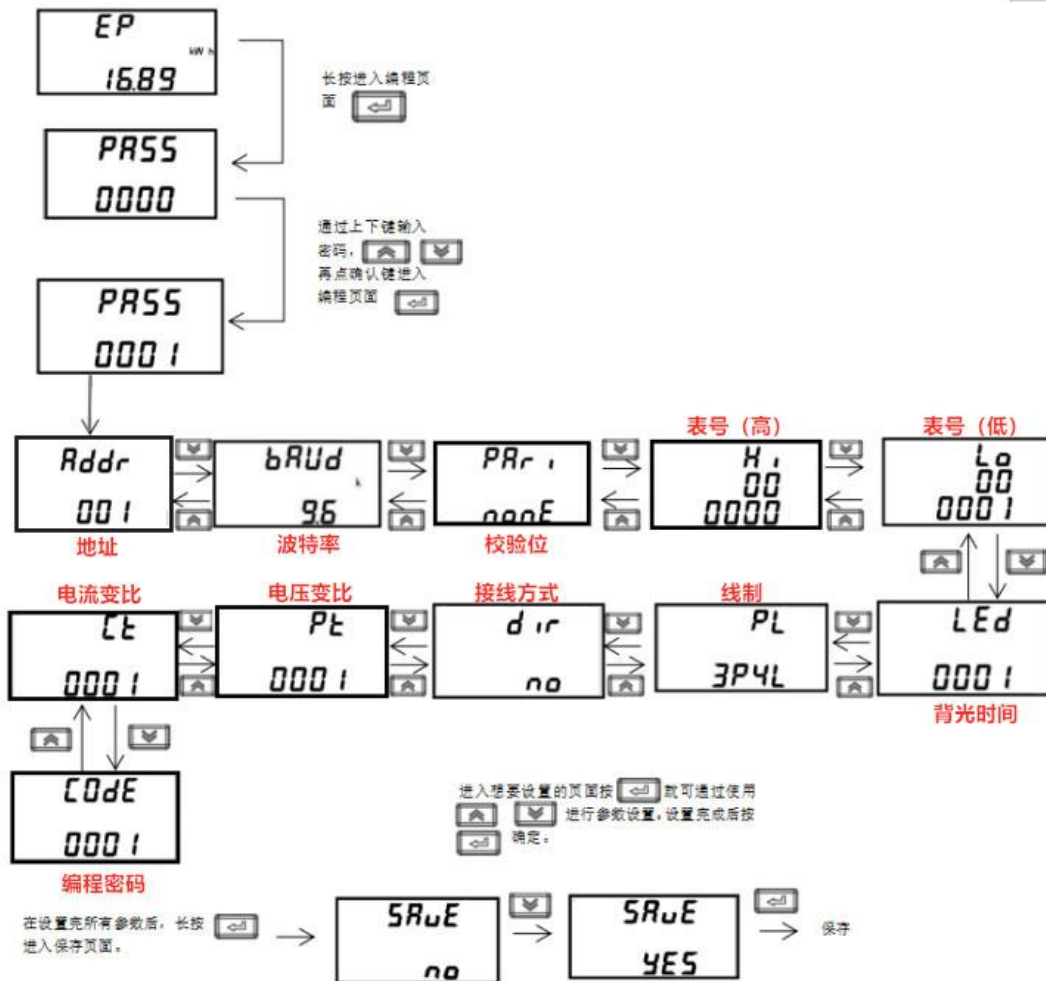

8.4 Data settings

Table 6 setting menu description

Num	Second menu		
	Symbol	Mean	Range
1	ADDR	Communicate's ADDR settings	1-247
2	Baud	Baud choose	1200、2400、4800、9600、19200、38400
3	Pari	Parity choose	None、Odd、Even
4	LED	Backlight time	1-255minutes, 0 means always on
5	PL	Wiring sample	3 phase 4 wires 3 phase 3 wires
6	DIR	direction of current	no- yes-
8	EF-E	time-sharing measurement function	EF-Function on E-Function off
9	Pt	Voltage transformer settings	1-9999
10	Ct	Current transformer	1-9999

		settings	
11	CoDE	Code settings	1-9999
12	PHAS	Phase angle calculation method	No-Angle between each current and each voltage Yes-Angle between three-phase current and phase a voltage
13	nost	Starting power shield	Shielding range, 0.1-2.0%(*UnIn)

9 Communication description

The meter adapts MODBUS-RTU protocol, and the baud rate can be chosen from 1200bps,2400 bps,4800 bps,9600bps,19200bps and 38400 bps. The default parity is None.

The meter needs shielded twisted pair conductors to connect. Customers should consider the whole network's parameters such like communication wire's length, the direction, communication transformer and network cover range, etc.

Note:

- 1、Wiring should follow the wiring requirements;
- 2、Connect all the meter in the RS485 net work even some do not need to communication, which is benefit for error checking and testing;
- 3、Use two color wires in connecting wires and all the A port use the same color.
- 4、No longer than 1200 meters of RS485 bus line.

9.1 ADDR List

MODBUS-RTU protocol has 03H and 10H command to read and write registers respectively. The following chart is registers' address list.

Table 7 communication address list

Address	Variable	Length	R/W	Note
0000H	Current total active energy	4	R	UINT32 Keep 2 decimal places. Unit kWh (The data of voltage, current, power and electric energy are all measured data of the meter. Particularly, if there is a transformation ratio of the meter, the relevant data shall be multiplied by the corresponding transformation ratio.)
0002H	Current spike electric energy	4	R	
0004H	Current peak electric energy	4	R	
0006H	Current flat electric energy	4	R	
0008H	Current valley electric energy	4	R	
000AH	Current forward active total electric energy	4	R	
000CH	Current forward active spike electric energy	4	R	
000EH	Current forward active peak electric energy	4	R	
0010H	Current forward active flat electric energy	4	R	
0012H	Current forward active valley electric energy	4	R	
0014H	Current reversing active total electric energy	4	R	
0016H	Current reversing active spike electric energy	4	R	
0018H	Current reversing Active peak electric energy	4	R	
001AH	Current reversing active flat electric energy	4	R	

001CH	Current reversing Active valley electric energy	4	R	If the electric energy value is 1234, Pt is 10,CT is 20,Then E = $1234 * 0.01 * 10 * 20 = 2468.00\text{kwh}$.Other data are calculated as above.
001EH	Current total reactive electric energy	4	R	UINT32 Keep 2 decimal places Particularly, note the same as above.
0020H	Current total reactive spike electric energy	4	R	
0022H	Current total reactive peak electric energy	4	R	
0024H	Current total reactive flat electric energy	4	R	
0026H	Current total reactive valley electric energy	4	R	
0028H	Current forward reactive total electric energy	4	R	
002AH	Current forward reactive spike electric energy	4	R	
002CH	Current forward reactive spike electric energy	4	R	
002EH	Current forward reactive flat electric energy	4	R	
0030H	Current forward reactive valley electric energy	4	R	
0032H	Current reversing reactive total electric energy	4	R	
0034H	Current reversing reactive spike electric energy	4	R	
0036H	Current reversing reactive peak electric energy	4	R	
0038H	Current reversing reactive flat electric energy	4	R	
003AH	Current reversing reactive valley electric energy	4	R	
003CH	Time: second、 minute	2	R/W	
003DH	Time: hour、 day	2	R/W	
003EH	Time: month、 year	2	R/W	
003FH	Address (high 8 bit) Baud (low 8 bit)	2	R/W	(baud) : 0: 1200 1: 2400 2: 4800 3: 9600 4: 19200 5: 38400
0040H	pulse constant	2	R	
0041H	First time zone time period number Start date of the first time zone: Day	2	R/W	Time zone number: 1: First time zone 2: Second time zone 3: Third time zone 4: Fourth time zone
0042H	Start date of the first time zone: month Second time zone time period number	2	R/W	
0043H	Start date of the second time zone: day Start date of the second time zone: month	2	R/W	
0044H	Third time zone time period number Start date of the third time zone: day	2	R/W	
0045H	Start date of the third time zone: month Fourth time zone time period number	2	R/W	

0046H	Start date of the fourth time zone: day Start date of the fourth time zone: month	2	R/W	
0047H-0060H	Reserve			
0061H	Voltage of A phase	2	R	UINT16 Resolution: 0.1V
0062H	Voltage of B phase	2	R	
0063H	Voltage of C phase	2	R	
0064H	Current of A phase	2	R	UINT16 Resolution: 0.01A
0065H	Current of B phase	2	R	
0066H	Current of C phase	2	R	
0067H-0076H	Reserve			
0077H	frequency	2	R	Resolution: 0.01
0078H	Voltage between A-B	2	R	UINT16 Resolution: 0.1V
0079H	Voltage between C-B	2	R	
007AH	Voltage between A-C	2	R	
007BH	Forward active maximum demand	2	R	Resolution: 0.001
007CH	Time of occurrence for the forward active maximum amount:minute、hour	2	R	
007DH	Time of occurrence for the forward active maximum amount:day、month	2	R	
007EH	Reversing active maximum demand	2	R	
007FH	Time of occurrence for the Reversing active maximum demand amount:minute、hour	2	R	
0080H	Time of occurrence for the Reversing active maximum demand amount:day、month	2	R	
0081H	Maximum forward demand for reactive power	2	R	
0082H	Time of occurrence for the forward reactive maximum amount:minute、hour	2	R	
0083H	Time of occurrence for the forward reactive maximum amount:day、month	2	R	
0084H	Maximum reversing demand for reactive power	2	R	
0085H	Time of occurrence for the reversing reactive maximum amount:minute、hour	2	R	
0086H	Time of occurrence for the reversing reactive maximum amount:day、month	2	R	
0087H	Forward active electric energy of A phase	4	R	
0089H	Forward active electric energy of B phase	4	R	
008BH	Forward active electric energy of C phase	4	R	
008DH	PT	2	R/W	
008EH	CT	2	R/W	
008FH	Reserve			
0092H	Zero sequence current	2	R	Resolution: 0.01A

0093H	Voltage imbalance	2	R	UINT16 Resolution: 0.001
0094H	Current imbalance	2	R	
0095H	Parity bit (high 8 bit) Stop bit (low 8 bit)	2	R/W	(parity bit) : 0: (None) 1: (Odd) 2: (Even) (stop bit) : 0: (one stop bit) 1: (two stop bit)
0096H-0098H	Reserve			
0099H-009EH	DL/T645Address	12	R/W	BCD code
009FH-00A5H	reserve			
00A6H	Code	2	R/W	1-9999
00A7H-00B1	reserve			
00B2H ... 00BAH	9-14 period of time Parameters setting information			The first time list
00BBH ... 00C3H	9-14 period of time Parameters setting information			The second time list
00C4H-00C9H	Reserve			
00CAH	The back light time	2	R/W	1-255minutes, 0 means always on
00CBH-0120H	Reserve			
0121H	Daily frozen time:Hour	2	R/W	
0122H	Monthly frozetime:day、hour	2	R/W	
0123H-0163H	Reserve			
0164H	Active power of A phase	4	R	INT32 Resolution: 0.001kW
0166H	Active power of B phase	4	R	
0168H	Active power of C phase	4	R	
016AH	Total active power	4	R	
016CH	Reactive power of A phase	4	R	INT32 Resolution: 0.001kvar
016EH	Reactive power of B phase	4	R	
0170H	Reactive power of C phase	4	R	
0172H	Total reactive power	4	R	
0174H	Apparent power of A phase	4	R	UINT32 Resolution: 0.001kVA
0176H	Apparent power of B phase	4	R	
0178H	Apparent power of C phase	4	R	
017AH	Total apparent power	4	R	
017CH	Power factor of A phase	2	R	INT16

017DH	Power factor of B phase	2	R	Resolution: 0.001
017EH	Power factor of C phase	2	R	
017FH	Total power factor	2	R	
0180H	Maximum forward active demand a day	2	R	Resolution: 0.001 Occur time:minute、hour
0181H	Occur time:minute、hour	2	R	
0182H	Maximum reversing active demand a day	2	R	
0183H	Maximum reversing active demand a day	2	R	
0184H	Maximum forward reactive demand a day	2	R	
0185H	Occur time:minute、hour	2	R	
0186H	Maximum Reverse Reactive Power Demand	2	R	
0187H	Occur time:minute、hour	2	R	
0188H	Maximum forward active demand last day	2	R	
0189H	Occur time:minute、hour	2	R	
018AH	Maximum reversing active demand last day	2	R	
018BH	Occur time:minute、hour	2	R	
018CH	Maximum forward reactive demand last day	2	R	
018DH	Occur time:minute、hour	2	R	
018EH	Maximum reversing reactive demand last day	2	R	
018FH	Occur time:minute、hour	2	R	
0190H	Maximum forward active demand last 2 days	2	R	
0191H	Occur time:minute、hour	2	R	
0192H	Maximum reversing active demand last 2 days	2	R	
0193H	Occur time:minute、hour	2	R	
0194H	Maximum forward reactive demand last 2 days	2	R	
0195H	Occur time:minute、hour	2	R	
0196H	Maximum reversing reactive demand last 2 days	2	R	
0197H	Occur time:minute、hour	2	R	
0198H	Current forward active demand	2	R	
0199H	Current reversing active demand	2	R	
019AH	Current forward reactive demand	2	R	
019BH	Current reversing reactive demand	2	R	
019CH-01FFH	Reserve			
0200H	Maximum voltage on A phase	2	R	
0201H	Occur date: month、day	2	R	
0202H	Occur time: hour、minute	2	R	
0203H	Maximum voltage on B phase and occur time	6	R	
0206H	Maximum voltage on C phase and occur time	6	R	
0209H	Maximum current on A phase and occur time	6	R	
020CH	Maximum current on B phase and occur time	6	R	
020FH	Maximum current on B phase and occur time	6	R	
0212H	Maximum active power on A phase	4	R	
0214H	Occur data: month、day	2	R	

0215H	Occur time: hour、minute	2	R
0216H	Maximum active power on B phase and occur time	8	R
021AH	Maximum active power on C phase and occur time	8	R
021EH	Maximum active power and occur time	8	R
0222H	Maximum reactive power on A phase and occur time	8	R
0226H	Maximum reactive power on B phase and occur time	8	R
022AH	Maximum reactive power on C phase and occur time	8	R
022EH	Maximum reactive power and occur time	8	R
0232H	Maximum apparent power on A phase and occur time	8	R
0236H	Maximum apparent power on B phase and occur time	8	R
023AH	Maximum apparent power on C phase and occur time	8	R
023EH	Maximum apparent power and occur time	8	R
0242H	Minimum voltage on A phase and occur time	6	R
0245H	Minimum voltage on B phase and occur time	6	R
0248H	Minimum voltage on C phase and occur time	6	R
024BH	Minimum current on A phase and occur time	6	R
024EH	Minimum current on B phase and occur time	6	R
0251H	Minimum current on C phase and occur time	6	R
0254H	Minimum active power on A phase and occur time	8	R
0258H	Minimum active power on B phase and occur time	8	R
025CH	Minimum active power on C phase and occur time	8	R
0260H	Minimum active power and occur time	8	R
0264H	Minimum reactive power on A phase and occur time	8	R
0268H	Minimum reactive power on B phase and occur time	8	R
026CH	Minimum reactive power on C phase and occur time	8	R
0270H	Minimum reactive power and occur time	8	R
0274H	Minimum apparent power on A phase and occur time	8	R
0278H	Minimum apparent power on B phase and occur time	8	R

027EH	Minimum apparent power on C phase and occur time	8	R	
0280H	Minimum apparent power and occur time	8	R	
0285H-1FFFH	Reserve			
F009H	Device model	2	R	A400(HEX)

9.2 Floating point electrical parameter data

Table 8 Float data communication address list

Address	Name	Length	R/W	Note
Secondary side data without multiplication of the variable ratio				
5300H	Voltage of A phase	4	R	Float Unit:V
5302H	Voltage of B phase	4	R	
5304H	Voltage of C phase	4	R	
5306H	Voltage between A-B	4	R	
5308H	Voltage between C-B	4	R	
530AH	Voltage between A-C	4	R	
530CH	Current of A phase	4	R	Float Unit:A
530EH	Current of B phase	4	R	
5310H	Current of C phase	4	R	
5312H	Active power of A phase	4	R	Float Unit:W
5314H	Active power of B phase	4	R	
5316H	Active power of C phase	4	R	
5318H	Total active power	4	R	
531AH	Reactive power of A phase	4	R	Float Unit:var
531CH	Reactive power of B phase	4	R	
531EH	Reactive power of C phase	4	R	
5320H	Total reactive power	4	R	
5322H	Apparent power of A phase	4	R	Float Unit:VA
5324H	Apparent power of B phase	4	R	
5326H	Apparent power of C phase	4	R	
5328H	Total apparent power	4	R	
532AH	Power factor of A phase	4	R	Float
532CH	Power factor of B phase	4	R	
532EH	Power factor of C phase	4	R	
5330H	Total power factor	4	R	
5332H	frequency	4	R	Float Unit:Hz
5334H	zero line current	4	R	Float Unit:A
Primary side data that has been multiplied by the variable ratio				
0800H	Voltage of A phase	4	R	Float Unit:V
0802H	Voltage of B phase	4	R	
0804H	Voltage of C phase	4	R	
0806H	Voltage between A-B	4	R	

0808H	Voltage between C-B	4	R	
080AH	Voltage between A-C	4	R	
080CH	Current of A phase	4	R	Float Unit:A
080EH	Current of B phase	4	R	
0810H	Current of C phase	4	R	
0812H	zero line current	4	R	
0814H	Active power of A phase	4	R	Float Unit:kW
0816H	Active power of B phase	4	R	
0818H	Active power of C phase	4	R	
081AH	Total active power	4	R	
081CH	Reactive power of A phase	4	R	Float Unit:kvar
081EH	Reactive power of B phase	4	R	
0820H	Reactive power of C phase	4	R	
0822H	Total reactive power	4	R	
0824H	Apparent power of A phase	4	R	Float Unit:kVA
0826H	Apparent power of B phase	4	R	
0828H	Apparent power of C phase	4	R	
082AH	Total apparent power	4	R	
082CH	Power factor of A phase	4	R	Float
082EH	Power factor of B phase	4	R	
0830H	Power factor of C phase	4	R	
0832H	Total power factor	4	R	
0834H	frequency	4	R	Float Unit:Hz
0836H	Voltage imbalance	4	R	Float Unit:0.1
0838H	Current imbalance	4	R	Float Unit:0.1
083AH	Current forward active demand	4	R	Float Unit: kW
083CH	Current reversing active demand	4	R	
083EH	Current forward reactive demand	4	R	Float Unit:kvar
0840H	Current reversing reactive demand	4	R	
0842H	Current total active energy	4	R) UIN32 Resolution: 0.1kWh Primary side data
0844H	Current spike electric energy	4	R	
0846H	Current peak electric energy	4	R	
0848H	Current flat electric energy	4	R	
084AH	Current valley electric energy	4	R	
084CH	Current forward active total electric energy	4	R	
084EH	Current forward active spike electric energy	4	R	
0850H	Current forward active peak electric energy	4	R	
0852H	Current forward active flat electric energy	4	R	
0854H	Current forward active valley electric energy	4	R	
0856H	Current reversing active total electric energy	4	R	
0858H	Current reversing active spike electric energy	4	R	
085AH	Current reversing Active peak electric energy	4	R	
085CH	Current reversing active flat electric energy	4	R	

085EH	Current reversing Active valley electric energy	4	R	UINT32 Resolution: 0.1kvarh Primary side data
0860H	Current total reactive electric energy	4	R	
0862H	Current total reactive spike electric energy	4	R	
0864H	Current total reactive peak electric energy	4	R	
0866H	Current total reactive flat electric energy	4	R	
0868H	Current total reactive valley electric energy	4	R	
086AH	Current forward reactive total electric energy	4	R	
086CH	Current forward reactive spike electric energy	4	R	
086EH	Current forward reactive spike electric energy	4	R	
0870H	Current forward reactive flat electric energy	4	R	
0872H	Current forward reactive valley electric energy	4	R	
0874H	Current reversing reactive total electric energy	4	R	
0876H	Current reversing reactive spike electric energy	4	R	
0878H	Current reversing reactive peak electric energy	4	R	
087AH	Current reversing reactive flat electric energy	4	R	
087CH	Current reversing reactive valley electric energy	4	R	

9.3

History energy frozen time and history energy energy date

DEMR-AC3's registers on frozen by day and by month.

Table 9 Frozen time communication address

Address	Name	R/W	Note
0121H	Frozen time by day	R/W	Null (High byte) Hour(Low byte)
0122H	Frozen time by month	R/W	Day(High byte) Hour(Low byte)

DEMR-AC3 can achieve the history energy statistic in last 48 months and last 90days. (Each tariff rate of energy can be recorded.)The history energy record can be read by assemblage and the length of whole part is 68 byte (34 registers), and the list below is the registers' name.

Table 10 History energy communication address

Address	Name	Data list	Name	Note
6000H	Assemblage of last 1 month demand and energy	6000H	Frozen time:YY-MM	
6022H	Assemblage of last 2 months demand and energy	6001H	Frozen time: DD-hh	
...	...	6002H	Total active energy	kWh UINT32
6BD2H	Assemblage of last 48 months demand and energy	6004H	Spike active energy	
reserve	reserve	6006H	Peak active energy	

7000H	Assemblage of last 1 day demand and energy	6008H	Flat active energy	Keep 2 decimal places (Secondary side data)
7022H	Assemblage of last 2days demand and energy	600AH	Valley active energy	
...	...	600CH	Total reactive energy	Kvarh UINT32 Keep 2 decimal places (Secondary side data)
763EH	Assemblage of last 90days demand and energy	600EH	Spike reactive energy	
		6010H	Peak reactive energy	
		6012H	Flat reactive energy	
		6014H	Valley reactive energy	
		6016H	Total amount of phase A forward active energy	kWh UINT32 Keep 2 decimal places (Secondary side data)
		6018H	Total amount of phase B forward active energy	
		601AH	Total amount of phase C forward active energy	
		601CH	Maximum active demand	Resolution: 0.001kW (Secondary side data)
		601DH	Occurrence time: mm-hh	
		601EH	Occurrence time : DD-MM	
		601FH	Maximum reactive demand	Resolution: 0.001kvar (Secondary side data)
		6020H	Occurrence time: mm-hh	
		6021H	Occurrence time: DD-MM	

9.4 Sub-harmonic data

DEMR-AC3 can measure harmonics, statistics split-phase 2-31st harmonic voltage and current, total harmonic distortion rate, split-phase harmonic voltage and current, split-phase harmonic active power and reactive power, split-phase fundamental current and voltage, split-phase fundamental active and power reactive power.

Table 11 Harmonics data address list

Address	Name	Length(byte)	R/W	Note
05DDH	THDUa	2	R	Total distortion rate of voltage and current on each phase UINT16 Resolution: 0.01%
05DEH	THDUb	2	R	
05DFH	THDUc	2	R	
05E0H	THDIa	2	R	
05E1H	THDIb	2	R	
05E2H	THDIc	2	R	
05E3H	THUa	2×30	R	Harmonic voltage on 2 nd -31 st UINT16 Resolution: 0.01%
0601H	THUb	2×30	R	
061FH	THUc	2×30	R	
063DH	THIa	2×30	R	Harmonic current on 2 nd -31 st UINT16 Resolution: 0.01%
065BH	THIb	2×30	R	
0679H	THIc	2×30	R	
0697H	Fundamental voltage on A phase	2	R	UINT16 Resolution: 0.1V
0698H	Fundamental voltage on B phase	2	R	
0699H	Fundamental voltage on C phase	2	R	

069AH	Harmonic voltage on A phase	2	R	UINT16 Resolution: 0.01A
069BH	Harmonic voltage on B phase	2	R	
069CH	Harmonic voltage on C phase	2	R	
069DH	Fundamental current on A phase	2	R	
069EH	Fundamental current on B phase	2	R	
069FH	Fundamental current on C phase	2	R	
06A0H	Harmonic current on A phase	2	R	
06A1H	Harmonic current on B phase	2	R	
06A2H	Harmonic current on C phase	2	R	
06A3H	Fundamental active power on A phase	2	R	INT16 Resolution: 0.001kW
06A4H	Fundamental active power on B phase	2	R	
06A5H	Fundamental active power on C phase	2	R	
06A6H	Fundamental active power	2	R	
06A7H	Fundamental reactive power on A phase	2	R	INT16 Resolution: 0.001kvar
06A8H	Fundamental reactive power on B phase	2	R	
06A9H	Fundamental reactive power on C phase	2	R	
06AAH	Fundamental reactive power	2	R	
06ABH	Harmonic active power on A phase	2	R	INT16 Resolution: 0.001kW
06ACH	Harmonic active power on B phase	2	R	
06ADH	Harmonic active power on C phase	2	R	
06AEH	Harmonic active power	2	R	
06AFH	Harmonic reactive power on A phase	2	R	INT16 Resolution: 0.001kvar
06B0H	Harmonic reactive power on B phase	2	R	
06B1H	Harmonic reactive power on C phase	2	R	
06B2H	Harmonic reactive power	2	R	

9.5 SOE SOE Record

Address	Name	Data list	Name
3001H	Last event record	0000H	Occur date: YY-MM
3002H	Last 2 event record	0001H	Occur time: DD-hh
...	...	0002H	Occur time: mm-ss

3064H	Last 100 event record
-------	-----------------------

0004H	Event number
0005H	Event details
0006H	Reserve

Event num	Name	Details	Note
0100	Power on		
0200	Clear	0001	Clear current energy
		0002	Clear history energy on Flash
		0003	Clear maximum demand
		0004	Clear history energy
		0005	Clear maximum value on a period
		0006	Clear out
0700	Time calibration		

Example: The address is 001 at present, and we send the code: 01 03 30 01 00 06 9B 08 to get the last event record, and the slave station will give back: 01 03 0C 12 01 08 0A 01 01 (2018/1/8 10:1:1) 01 00 (powered) 00 00 (no details) 00 00 (reserved) 80 23